

**NOTICE & AGENDA
CITY COUNCIL
FOLLOWED BY PRYOR PUBLIC WORKS AUTHORITY MEETING
CITY OF PRYOR CREEK, OKLAHOMA
TUESDAY, MARCH 3, 2026 AT 6:00 PM**

AS REQUIRED BY THE OKLAHOMA OPEN MEETING ACT, NOTICE IS HEREBY GIVEN THAT THE CITY COUNCIL OF THE CITY OF PRYOR CREEK, OKLAHOMA WILL MEET IN REGULAR SESSION AT 6:00 P.M. ON THE ABOVE DATE IN THE COUNCIL CHAMBER UPSTAIRS AT CITY HALL, 12 NORTH ROWE STREET IN PRYOR CREEK, OKLAHOMA. A MEETING OF THE PRYOR PUBLIC WORKS AUTHORITY WILL FOLLOW IMMEDIATELY. ANYONE NEEDING SPECIAL ACCOMMODATIONS TO ATTEND SHOULD CALL (918) 825-0888.

CITY COUNCIL

1. Call to Order, Prayer, Pledge of Allegiance, Roll.
2. Petitions from the Audience. (Limited to 5 minutes, must request in advance.)
3. Department Head Reports if needed:
 - a. Building Inspector
 - b. Emergency Management
 - c. Fire
 - d. Golf
 - e. Library
 - f. Parks / Cemetery
 - g. Police / Animal Shelter
 - h. Recreation Center
 - i. Street
 - j. City Clerk
4. Consent Agenda. (Consent items are to be voted on for approval or denial by one single motion without discussion. Any Council member wishing to discuss an item may request it be removed and placed on the regular agenda. Only those items removed will be read aloud.)
 - a. Approve minutes of the February 17th, 2026 Council Meeting.
 - b. Approve claims for purchase orders through March 3rd, 2026.
 - c. Approve payroll purchase orders through March 13th, 2026.
 - d. Approve amending minutes previously adopted from the February 3rd, 2026 regular meeting to correct item 4d pertaining to an expenditure in the amount of \$15,293.59 to Stewart Martin Kubota of Broken Arrow for a Commercial Kawasaki Z700 Gas Mower with extended warranty and canopy to be paid from Facilities Capital Outlay Account #44-445-5426 to reflect a corrected total expenditure of \$15,993.59.
 - e. Approve Mayor to sign an engagement letter with Hood & Associates for the 2025 Audit.
 - f. Approve an expenditure in the amount of \$20,500.00 to Hood & Associates for the 2025 Audit from General Outside Services - Auditor Account #02-201-5072.
 - g. Approve an expenditure in the amount of \$41,398.25 to OMAG for Property Insurance Policy #PRO1400033010 from General Insurance - Property Account #02-201-5045. This is the fourth-quarter payment.
 - h. Approve an expenditure in the amount of \$30,265.00 to OMAG for General Liability/Auto Policy #GLA1400017010 from General Insurance - Fleet Account #02-201-5043. This is the fourth-quarter payment.
 - i. Approve an expenditure in the amount of \$3,607.98 to Backward Audio, LLC for installation and programming to upgrade streaming equipment in the Council Chambers to be paid from City Hall Capital Outlay Account #44-445-5427.
 - j. Approve an expenditure in the amount of \$18,517.68 to Dell Technologies for six (6) Dell Pro Rugged 14 RB14250 laptops and six (6) Havis Lind 120W power supplies to be paid from Police Misc. Cherokee Nation Donations Account #96-965-5502. This will be an OMNIA - National Cooperative Purchasing Alliance Price - Contract Code #C000001019611.
 - k. Approve an expenditure in the amount of \$30,423.72 to Motorola Solutions for six (6) APX N30 Portable Radios to be paid from Police Misc. Cherokee Nation Donations Account #96-965-5502. This will be a State Contract Price SW1053M through OMES.
 - l. Accept the resignation of Bret LoCoco from the Pryor Creek Police Department effective March 1st, 2026.

- m. Approve declaring surplus the following items from the Pryor Creek Police Department and listing them for sale on the PurpleWave Auction site.

Unit	Year	Make	Model	Tag	VIN
14	2015	Chevy	Tahoe	C125205	1GNLC2EC3FR629394
15	2015	Chevy	Tahoe	C125206	1GNLC2EC4FR629520
17	2015	Chevy	Tahoe	C125208	1GNLC2EC0FR629384
102	2015	Ford	Explorer	C125203	1FM5K7883FGA45313

- n. Approve an expenditure in the amount of \$50,375.00 to Infrastructure Solutions Group for Invoice PRY-24-02-01 in reference to the Elliott Street Drainage Improvements to be paid from Street & Drainage Projects - Miscellaneous Account #14-145-5092.
- 5. Mayor’s Report: (Items possibly requiring discussion and action.)
 - a. Presentation from Pryor Public School Superintendent Dr. Lisa Muller regarding the proposed upcoming school Bond issue.
 - b. Discussion and possible action regarding acknowledgment of the June 30th, 2024 Independent Auditor’s Report of Financial Statements for the City of Pryor Creek, Oklahoma as presented by Violet Kirkendall of Hood & Associates, PC Certified Public Accountants.
 - c. Presentation and discussion regarding the Mid-Year Financial Status from City Accountant Jeff Kolker.
 - d. Discussion and possible action to allow the City Clerk's Office to accept applications for the Deputy Clerk position to fill the vacancy created by the resignation of Sara Catron.
 - e. Discussion and possible action regarding approval of the EDTA recommendation to transfer \$62,000 from Fund 68 Account #68-685-5342 (*Transfer to Other Funds*) to the EDTA Festival Account #98-000-4545 (*Transfers From Fund 98*). These funds will be used for the 2026 Music Festival in the downtown corridor.
 - f. Discussion and possible action regarding the implementation and management oversight of a Municipal Commuter Vehicle Policy authorizing the commuting of a 30 mile radius from the department parking lots to the address on file with the City Clerk's office.
 - g. Discussion and possible action to approve Infrastructure Solutions Group to go out for bids for 2025-2026 Street Improvement Projects.
- 6. City Attorney’s Report: (Items possibly needing action on requests or recommendations.)
 - a. Third and final reading of Ordinance #2026-1, an Ordinance of the City of Pryor Creek, Oklahoma granting a non-exclusive permit to Clarity Telecom, LLC (D/B/A Bluepeak) for the construction and operation of a cable system.
- 7. Committee Reports: (Items, such as next meeting date, needing to be reported. No open discussions allowed. Any items requiring discussion are to be added to the Mayor’s report prior to posting of agenda.)
 - a. Budget and Personnel.
 - b. Streets and Maintenance.
 - c. Ordinance and Insurance.
- 8. Unforeseeable Business. (Any matter not reasonably foreseen prior to posting of agenda.)
- 9. Adjourn.

PRYOR PUBLIC WORKS AUTHORITY

- 1. Call to Order.
- 2. Approve minutes of the February 17th, 2026 meeting.
- 3. Approve claims for purchase orders for the Pryor Public Works Authority through March 3rd, 2026.
- 4. Unforeseeable Business. (Any matter not reasonably foreseen prior to posting of agenda.)
- 5. Adjourn.

FILED FEBRUARY 27th, 2026 AT 5:00 P.M. BY MAYOR ZAC DOYLE. _____

POSTED ON THE BULLETIN BOARD AT CITY HALL, 12 NORTH ROWE STREET, PRYOR CREEK, OKLAHOMA
 FEBRUARY 27th, 2026 AT 5:00 P.M. BY CITY CLERK HANNAH MORRIS. _____

**MINUTES
CITY COUNCIL MEETING
FOLLOWED BY PRYOR PUBLIC WORKS AUTHORITY MEETING
CITY OF PRYOR CREEK, OKLAHOMA
TUESDAY, FEBRUARY 17TH, 2026 AT 6:00 P.M.**

The City Council of the City of Pryor Creek, Oklahoma met in regular session on the above date and time in the Council Chamber upstairs at City Hall, 12 North Rowe Street in Pryor Creek, Oklahoma. This meeting was followed immediately by a meeting of the Pryor Public Works Authority. Notice of these meetings was posted on the East bulletin board located outside to the South of the entrance doors and the City website at www.pryorcreek.org. Notice was also emailed to the Council members.

1. CALL TO ORDER, PRAYER, PLEDGE OF ALLEGIANCE, ROLL CALL.

Mayor Zac Doyle called the meeting to order at 6:00 p.m. The Prayer and Pledge of Allegiance were led by Lori Bradshaw. Roll Call was conducted by City Clerk Hannah Morris. Council members present included Terry Lamar, Choya Shropshire, Lori Bradshaw, Kenneth Brashears, Tyler Brown, Charles Tramel, Steve Brown and Bruce Smith. Members absent: none.

Department Heads and other City Officials present: Chase McBride, Jeremy Cantrell, Justin Couch, Kevin Tramel, Dennis Bowman, Cari Rerat and Lori Ballew.

Others present: Brian Dinsmore, Matt Copeland, Bill Dinsmore, Susan Wilcox, Kimmie Shropshire, David Shaulis, Jimmy Tramel, Drew Stott, Charlene Kendrick, Barbara Drum, Richard Bradshaw, Jared Crisp, Autumn Graybill, Gilbert Graybill, Nena Roberts and Marshel Morrison.

2. PETITIONS FROM THE AUDIENCE:

(Limited to 5 minutes, must request in advance.)

Charlene Kendrick, Barbara Drum and Richard Bradshaw announced the 76th Annual Miss Mayes County Pageant benefiting the Sertoma Club. They stated that the pageant will take place Saturday, March 7th, 2026 at 6:00 p.m. at Avra Performing Arts Center. They stated that the organization has awarded 5,000 scholarships through the event and all proceeds benefit local seniors through free transportation, hot meals and more provided by the Sertoma Club.

3. DISCUSSION AND POSSIBLE ACTION ON CONSENT AGENDA.

(Consent items are to be voted on for approval or denial by one single motion without discussion. Any Council member wishing to discuss an item may request it be removed and placed on the regular agenda. Only those items removed will be read aloud.)

- a. Approve minutes of the February 3rd, 2026 Council meeting.
- b. Approve payroll purchase orders through February 27th, 2026.
- c. Approve claims for purchase orders through February 17th, 2026.

<u>FUNDS</u>	<u>PURCHASE ORDER NUMBER</u>	<u>TOTALS</u>
GENERAL	911575B - 2520251865	\$274,916.67
STREET & DRAINAGE	2520252053 - 2520251845	\$21,760.30
GOLF COURSE	2520251877 - 2520251875	\$5,179.97
CAPITAL OUTLAY	2520251583 - 911618B	\$78,187.41
REAL PROPERTY ACQUISITION RES.	2520251861 - 2520251880	\$9,869.26
RECREATION CENTER	2520251888 - 2520251957	\$10,401.15
P.P.W.A. SINKING FUND	911613B - 911614B	\$8,319.39
E-911	2520251958	\$195.62
DONATIONS & EARMARKED MONIES	2520251688 - 2520251919	\$26,068.54
EDTA	2520251953	\$9,000.00
TOTAL		\$443,898.31

NO NEW BLANKETS

- d. Approve a Hotel/Motel Grant Application from the Pryor Area Arts and Humanities Council for the Pryor Creek Comic Convention to be held March 7th, 2026 in the amount of \$1,000.00.
- e. Discussion and possible action on approval of a 3% rate increase from Pryor Waste & Recycling, LLC for all refuse pick-up beginning March 1st, 2026, consistent with the mutual agreement of October 2007.
- f. Approve expenditure in the amount of \$5,043.00 to Hood & Associates CPAs for final progress billing of audit services for the 2024 Fiscal Year Audit from Outside Services - Auditor Account #02-201-5072. The Auditor Agreement was approved on December 2nd, 2025.
- g. Approve a reimbursement of funds in the amount of \$57,462.00 to be paid to the Oklahoma Office of the Attorney General from Donations and Grants Account

#02-000-4251, as a return of unspent funds from the OAG Opioid Abatement Grant for the Pryor Police Department.

- h. Approve an expenditure in the amount of \$7,094.87 to Motorola Solutions for Video Manager EL / Body Worn Camera Annual License to be paid from Police Gas & Oil Account #02-215-5102.
- i. Approve an expenditure in the amount of \$5,130.13 to Pryor Chevrolet for parts and labor related to the repair of a 2008 Chevrolet Silverado to be paid from Street Repair and Maintenance Account #14-145-5342.

Motion was made by Brashears, second by S. Brown to approve the consent agenda less item e. Voting yes: Lamar, Shropshire, Bradshaw, Brashears, T. Brown, Tramel, S. Brown and Smith. Voting no: none. *Motion passed.*

Mayor moved to Mayor's Report.

4. MAYOR'S REPORT

(These are items possibly requiring discussion and action.)

4a. Discussion and possible action to accept a bid in the amount of \$312,336.00 from Yamaha Golf-Car Company for the purchase of 60 new golf carts and three utility carts at the Pryor Creek Golf Course in the best interest of the city. One other bid was received from Clear Creek Golf Car and Utility Vehicles in the amount of \$237,345.00.

Motion was made by Shropshire, second by Brashears to accept a bid in the amount of \$312,336.00 from Yamaha Golf-Car Company for the purchase of 60 new golf carts and three utility carts at the Pryor Creek Golf Course in the best interest of the city.

Motion was amended by Shropshire, second by Brashears to accept a bid in the amount of \$237,345.00 from Clear Creek Golf Car and Utility Vehicles for the purchase of 60 new golf carts and three utility carts at the Pryor Creek Golf Course to be paid from Golf Capital Outlay Cart Leasing Account #41-415-5413. Voting yes: Shropshire, Bradshaw, Brashears, T. Brown, Tramel, S. Brown, Smith and Lamar. Voting no: none. *Motion passed.*

4b. Discussion and possible action to accept a lease purchase quote for 60 new golf carts and three utility carts for a 48-month term. Quotes received: Bank of Commerce at a rate of 3.98% and RCB Bank at a rate of 4.48%.

Motion was made by Shropshire, second by Tramel to accept a lease purchase quote for 60 new golf carts and three utility carts for a 48-month term from Bank of Commerce at a rate of 3.98%. Voting yes: Bradshaw, Brashears, T. Brown, Tramel, Smith, Lamar and Shropshire. Abstaining, counting a no vote: S. Brown. Voting no: none. *Motion passed.*

4c. Discussion and possible action to terminate contract with TimeClocks Plus (TCP) term ending March 31st, 2026 (written notice required by contract 30 days prior to renewal).

Motion was made by S. Brown, second by Brashears to approve terminating the contract with TimeClocks Plus (TCP) term ending March 31st, 2026. Voting yes: Brashears, T. Brown, Tramel, S. Brown, Smith, Lamar, Shropshire and Bradshaw. Voting no: none. *Motion passed.*

4d. Discussion and possible action regarding purchase of Time and Labor Software from Paylocity not to exceed \$10,000.00 to be paid from General Software Account #02-201-5260 to replace TimeClocks Plus (TCP).

Motion was made by Brashears, second by S. Brown to approve the purchase of Time and Labor Software from Paylocity not to exceed \$10,000.00 to be paid from General Software Account #02-201-5260 to replace TimeClocks Plus (TCP). Voting yes: Brashears, T. Brown, Tramel, S. Brown, Smith, Lamar, Shropshire and Bradshaw. Voting no: none. *Motion passed.*

4e. Discussion and possible action to hire Jackson Palma Branstetter as a B Operator at the Street Department, Range C, Step 1, to fill the vacancy created by the termination of Justin Wallace.

Motion was made by Shropshire, second by Bradshaw to approve hiring Jackson Palma Branstetter as a B Operator at the Street Department, Range C, Step 1, to fill the vacancy created by the termination of Justin Wallace. Voting yes: T. Brown, Tramel, S. Brown, Smith, Lamar, Shropshire, Bradshaw and Brashears. Voting no: none. *Motion passed.*

5. CITY ATTORNEY’S REPORT:

No report.

Mayor moved back to Consent Agenda item 3e.

3e. Discussion and possible action on approval of a 3% rate increase from Pryor Waste & Recycling, LLC for all refuse pick-up beginning March 1st, 2026, consistent with the mutual agreement of October 2007.

Motion was made by Tramel, second by Smith to discuss a 3% rate increase from Pryor Waste & Recycling, LLC for all refuse pick-up beginning March 1st, 2026, consistent with the mutual agreement of October 2007.

Bill Dinsmore, Brian Dinsmore, Matt Copeland and former mayor Jimmy Tramel presented a history of the agreement between the City and Pryor Waste and Recycling. The Council discussed customer service concerns, annexation coordination, contract transparency, and the requested 3% rate increase. Recycling costs, operational expenses, and potential future service changes were also addressed. The Council requested the full contract history and additional documentation for review before taking action. Voting yes: Tramel, S. Brown, Smith, Lamar, Shropshire, Bradshaw, Brashears and T. Brown. Voting no: none. *No action taken.*

6. COMMITTEE REPORTS:

(Items, such as next meeting date, needing to be reported. No open discussions. Any items requiring discussion are to be added to the Mayor’s report prior to posting of agenda.)

a. Budget and Personnel

Shropshire reported that the next meeting will be Tuesday, March 10th.

b. Ordinance and Insurance

T. Brown reported that the next meeting will be Tuesday, March 31st.

c. Street and Maintenance

Lamar reported that the next meeting will be Tuesday, February 24th.

7. UNFORESEEABLE BUSINESS.

(ANY MATTER NOT REASONABLY FORESEEN PRIOR TO POSTING OF AGENDA.)

There was no unforeseeable business.

8. ADJOURN.

Motion was made by Shropshire, second by Brashears to adjourn. Voting yes: S. Brown, Smith, Lamar, Shropshire, Bradshaw, Brashears, T. Brown and Tramel. Voting no: none.

PRYOR PUBLIC WORKS AUTHORITY

1. CALL TO ORDER.

Meeting was called to order at 7:58 p.m.

2. APPROVE MINUTES OF THE FEBRUARY 3RD, 2026 MEETING.

Motion was made by Shropshire, second by S. Brown to approve the minutes of the February 3rd, 2026 meeting. Voting yes: Smith, Lamar, Shropshire, Bradshaw, Brashears, T. Brown, Tramel and S. Brown. Voting no: none.

3. APPROVE CLAIMS FOR PURCHASE ORDERS FOR THE PRYOR PUBLIC WORKS AUTHORITY THROUGH FEBRUARY 17TH, 2026.

Motion was made by Brashears, second by Shropshire to approve claims for purchase orders for the Pryor Public Works Authority through February 17th, 2026. Voting yes: Lamar, Shropshire, Bradshaw, Brashears, T. Brown, Tramel, S. Brown and Smith. Voting no: none.

4. UNFORESEEABLE BUSINESS.

(ANY MATTER NOT REASONABLY FORESEEN PRIOR TO POSTING OF AGENDA.)

There was no unforeseeable business.

5. ADJOURN.

Motion was made by S. Brown, second by Brashears to adjourn at 8:00 p.m. Voting yes: Shropshire, Bradshaw, Brashears, T. Brown. Tramel, S. Brown, Smith and Lamar. Voting no: none.

MINUTES APPROVED BY MAYOR / P.P.W.A. CHAIRMAN ZAC DOYLE

MINUTES WRITTEN BY CITY CLERK HANNAH MORRIS

**MINUTES
CITY COUNCIL MEETING
FOLLOWED BY PRYOR PUBLIC WORKS AUTHORITY MEETING
CITY OF PRYOR CREEK, OKLAHOMA
TUESDAY, FEBRUARY 3RD, 2026 AT 6:00 P.M.**

The City Council of the City of Pryor Creek, Oklahoma met in regular session on the above date and time in the Council Chamber upstairs at City Hall, 12 North Rowe Street in Pryor Creek, Oklahoma. This meeting was followed immediately by a meeting of the Pryor Public Works Authority. Notice of these meetings was posted on the East bulletin board located outside to the South of the entrance doors and the City website at www.pryorcreek.org. Notice was also emailed to the Council members.

1. CALL TO ORDER, PRAYER, PLEDGE OF ALLEGIANCE, ROLL CALL.

Mayor Doyle called the meeting to order at 6:00 p.m. The Prayer and Pledge of Allegiance were led by Brashears. Roll Call was conducted by City Clerk Hannah Morris. Council members present included Terry Lamar, Choya Shropshire, Kenneth Brashears, Tyler Brown, Charles Tramel, Steve Brown and Bruce Smith. Members absent: Lori Bradshaw.

Department Heads and other City Officials present: Chase McBride, Jeremy Cantrell, Justin Couch, Kevin Tramel, Becki Sams-Benham, BK Young, Buddy Glenn, Dennis Bowman, Johnny Janzen, Cari Rerat, Mike Moore and Lori Ballew.

Others present: Gilbert Graybill, Autumn Graybill, Jimmy Lemmons, Bryant Shaver, Jeanette Anderson, Chad Morris, Susan Wilcox, Davis Shaulis, Kemmie Shropshire, Harper Meehan and Dale Burke.

2. PETITIONS FROM THE AUDIENCE:

(Limited to 5 minutes, must request in advance.)

There were no petitions from the audience.

3. DEPARTMENT HEAD REPORTS.

a. Building Inspector

Mayor Doyle reported on behalf of Kenny Young that there were 55 paid inspections and 24 additional inspections conducted with contractors and MUB during the month of January. He also reported that staff has been working on various abatement issues, including a significant project on Park Street, while providing zoning and planning information to homeowners and contractors regarding additions and outbuildings.

b. Emergency Management

Janzen reported that the recent snowstorm was managed successfully and resulted in better outcomes than initially expected despite the gritty nature of the snow. He also reported that while a few vehicles had to be recovered from the center median, there were no major disasters, and he credited the pre-event coordination meetings led by Chief Cantrell for the city's preparedness.

c. Fire

Chief Young reported that his crew successfully navigated the winter weather and expressed satisfaction with their performance. He also reported that the department is currently tracking well with their EMR and EMT refreshers, ensuring all personnel are up to date on their training.

d. Golf

Bowman reported that the golf course experienced its best January on record, which is highly unusual for the season. He also reported that maintenance crews are 80% ready for the spring season, having completed significant equipment repairs, tree work, and the removal of hogs that were damaging the turf. He shared a tournament schedule showing that half of the upcoming 12 events are dedicated to schools and youth participation.

e. Library

Rerat reported that while physical item additions were low in January due to vendor market changes, the library added nearly 3,000 digital items through its consortium. She also reported on upcoming programming, including a family movie night featuring *The Princess Bride* and the "Write Good" writers' group. Additionally, she noted that the recent Murder Mystery fundraiser hosted by Mayor Doyle and his wife was a success, with 28 attendees and three people correctly identifying the murderer.

f. Parks / Cemetery

Mayor Doyle reported on behalf of Frank Powell that work is continuing on the new bathrooms for the tennis courts and that donor recognition banners have been installed. He also reported that the city received a \$3,000.00 grant from the GRDA for a new ice machine for the concession stand and that a subcommittee has been formed to investigate the costs and implementation of a holiday light display for the next year.

g. Police / Animal Shelter

Cantrell reported that the department is currently investigating a recent shooting on Orphan Street where the victim was life-flighted to Tulsa in critical condition. He also reported that heavy fog in January led to several crashes on Highway 69 and 69A and noted that the department assisted with clearing streets during the heavy snowfall. Additionally, he highlighted a major fire at IMI in mid-January and announced an upcoming DUI saturation patrol and checkpoint scheduled for Super Bowl Sunday.

Sams-Benham reported that January was a difficult month, with 46 animals taken in and only 29 leaving the shelter. It was also reported that a pair of young dogs returned to the shelter before Christmas, including a Golden Retriever, were successfully adopted today.

h. Recreation Center

Moore reported that the local pickleball contingent, which now includes about 40 members, recently celebrated Kelly Tramel for winning a national championship in her division. He also reported that the facility's membership remains strong at 2,110 and that the center is preparing for its 20th Anniversary celebration on March 15th at 2:00 p.m., as well as a health fair scheduled for early June.

i. Street

Glenn reported that his crews worked extensively starting at 6:00 a.m. on Saturday to clear snow from main streets and sidewalks. He stated that the city intentionally avoids plowing residential side streets to prevent blocking citizens' driveways with heavy snow drifts, unless an emergency vehicle requires access. He also stated that they have completed a pipe installation on Dog Pound Road and a final walk-through for the Elliot Street project.

j. City Clerk

Morris reported that the December financials have been distributed and that a review of insurance schedules with department heads has identified several areas for cost savings. She also reported that the transition to ACH vendor payments is saving the city approximately \$2.00 per check, totaling roughly \$100 in savings per month. Finally, she encouraged the council and public to utilize the new website portal for records requests and noted that the full agenda packets can be found by clicking the speaker icon on the meeting calendar.

4. DISCUSSION AND POSSIBLE ACTION ON CONSENT AGENDA.

(Consent items are to be voted on for approval or denial by one single motion without discussion. Any Council member wishing to discuss an item may request it be removed and placed on the regular agenda. Only those items removed will be read aloud.)

- a. Approve minutes of the January 20th, 2026 Council meeting.
- b. Approve payroll purchase orders through February 13th, 2026.
- c. Approve claims for purchase orders through February 3rd, 2026.

FUNDS	PURCHASE ORDER NUMBER	TOTALS
GENERAL	2520251834 - 2520251714	\$130,968.89
STREET & DRAINAGE	2520251748 - 2520251571	\$172,721.99
GOLF COURSE	2520251724 - 2520251820	\$12,837.47
CAPITAL OUTLAY	2520251593 - 2520251746	\$8,782.49
REAL PROPERTY ACQUISITION RES.	2520251745 - 2520251802	\$1,303.93
RECREATION CENTER	2520251717 - 2520251831	\$30,688.21
PPWA SINKING FUND	911613B - 2520251788	\$4,242.89
E-911	2520251727	\$194.74
EDTA	2520251814 - 2520251849	\$25,250.00
	TOTAL	\$386,990.61
	NEW BLANKETS	
911618B	PREMIER SIGNS & DESIGN	\$8,500.00
	TOTAL	\$8,500.00

- d. Approve an expenditure in the amount of \$17,686.79 to Stewart Martin Kubota of Broken Arrow for a Commercial Kubota ZD1000 Diesel Mower with extended warranty and canopy to be paid from Facilities Capital Outlay Account #44-445-5426. Nine other mowers were priced and compared across multiple

dealers; see the attached comparison table. All prices are either Sourcewell or State Contract.

- e. Accept resignation of Thomas Ethan Conseen, Police Department, effective 02/13/2026.
- f. Approve an expenditure in the amount of \$2,789.88 to Bruckners Truck & Equipment Repair in Big Cabin for a Leaf Spring repair to the Street Department dump truck to be paid from Street Repair and Maintenance Account #14-145-5342.

Motion was made by Shropshire, second by Brashears to approve the consent agenda less items d and e. Voting yes: Lamar, Shropshire, Brashears, T. Brown, Tramel, S. Brown and Smith. Voting no: none. *Motion passed.*

4d. Approve an expenditure in the amount of \$17,686.79 to Stewart Martin Kubota of Broken Arrow for a Commercial Kubota ZD1000 Diesel Mower with extended warranty and canopy to be paid from Facilities Capital Outlay Account #44-445-5426. Nine other mowers were priced and compared across multiple dealers; see the attached comparison table. All prices are either Sourcewell or State Contract.

Motion was made by T. Brown, second by Brashears to approve an expenditure in the amount of \$17,686.79 to Stewart Martin Kubota of Broken Arrow for a Commercial Kubota ZD1000 Diesel Mower with extended warranty and canopy to be paid from Facilities Capital Outlay Account #44-445-5426.

Motion was amended by T. Brown, second by Brashears to approve an expenditure in the amount of \$15,993.59 to Stewart Martin Kubota of Broken Arrow for a Commercial Kawasaki Z700 Gas Mower with extended warranty and canopy to be paid from Facilities Capital Outlay Account #44-445-5426. Voting yes: Shropshire, T. Brown, S. Brown and Lamar. Voting no: Brashears, Tramel and Smith. *Motion passed.*

4e. Accept resignation of Thomas Ethan Conseen, Police Department, effective 02/13/2026. Motion was made by S. Brown, second by T. Brown to accept the resignation of Thomas Ethan Conseen, Police Department, effective 02/13/2026. Voting yes: Brashears, T. Brown, Tramel, S. Brown, Smith, Lamar and Shropshire. Voting no: none. *Motion passed.*

5. MAYOR'S REPORT

(These are items possibly requiring discussion and action.)

5a. Discussion and possible action to hire Bryant Shaver as a Patrolman with the Pryor Creek Police Department, Range J, Step 1, effective February 26th, 2026 to fill the vacancy created by the resignation of Thomas Conseen.

Motion was made by S. Brown, second by Tramel to approve hiring Bryant Shaver as a Patrolman with the Pryor Creek Police Department, Range J, Step 1, effective February 26th, 2026 to fill the vacancy created by the resignation of Thomas Conseen.

Motion was amended by S. Brown, second by Tramel to approve hiring Bryant Shaver as a Patrolman with the Pryor Creek Police Department, Range J, Step 2, effective February 26th, 2026 to fill the vacancy created by the resignation of Thomas Conseen. Voting yes: T. Brown, Tramel, S. Brown, Smith, Lamar, Shropshire and Brashears. Voting no: none. *Motion passed.*

5b. Discussion and possible action regarding PRY-24-02 Elliott Street Drainage Improvements Change Order #2 in the amount of \$6,800.00 to J & S Construction.

Motion was made by S. Brown, second by Shropshire to approve PRY-24-02 Elliott Street Drainage Improvements Change Order #2 in the amount of \$6,800.00 to J & S Construction. Voting yes: Tramel, S. Brown, Smith, Lamar, Shropshire, Brashears and T. Brown. Voting no: none. *Motion passed.*

5c. Discussion and possible action regarding an expenditure in the amount of \$135,571.18 to J & S Construction for PRY-24-02 Elliott Street Drainage Improvements Pay App #2 to be paid from Street & Drainage Projects - Miscellaneous Account #14-145-5092.

Motion was made by Shropshire, second by S. Brown to approve an expenditure in the amount of \$135,571.18 to J & S Construction for PRY-24-02 Elliott Street Drainage Improvements Pay App #2 to be paid from Street & Drainage Projects - Miscellaneous Account #14-145-5092. Voting yes: S. Brown, Smith, Lamar, Shropshire, Brashears, T. Brown and Tramel. Voting no: none. *Motion passed.*

Mayor moved to Addendum item 3.

**ADDENDUM
CITY COUNCIL MEETING
TUESDAY, FEBRUARY 3RD, 2026 AT 6:00 P.M.**

A3. Discussion and possible action to declare surplus the following item: one (1) 2018 Ford Explorer XLT police vehicle, Unit 101, License Plate CI38536, VIN 1FM5K8B84JGC13796, currently assigned as a School Resource Officer (SRO) vehicle.

Motion was made by S. Brown, second by Shropshire to approve declaring surplus the following item: one (1) 2018 Ford Explorer XLT police vehicle, Unit 101, License Plate CI38536, VIN 1FM5K8B84JGC13796, currently assigned as a School Resource Officer (SRO) vehicle. Voting yes: Smith, Lamar, Shropshire, Brashears, T. Brown, Tramel and S. Brown. Voting no: none. *Motion passed.*

A4. Discussion and possible action to sell the following surplus item to another governmental entity: one (1) 2018 Ford Explorer XLT police vehicle, Unit 101, License Plate CI38536, VIN 1FM5K8B84JGC13796, to the Mayes Emergency Services Trust Authority (MESTA) for the amount of \$10,000.00, upon declaration of the vehicle as surplus, as authorized by Oklahoma law and the Pryor Creek Ordinances governing the disposition of surplus municipal property, contingent upon approval by the MESTA Board at its meeting scheduled for February 10th, 2026, with sale proceeds to be deposited into Police Equipment Capital Outlay Account #44-445-5424.

Motion was made by S. Brown, second by Shropshire to approve selling the following surplus item to another governmental entity: one (1) 2018 Ford Explorer XLT police vehicle, Unit 101, License Plate CI38536, VIN 1FM5K8B84JGC13796, to the Mayes Emergency Services Trust Authority (MESTA) for the amount of \$10,000.00, upon declaration of the vehicle as surplus, as authorized by Oklahoma law and the Pryor Creek Ordinances governing the disposition of surplus municipal property, contingent upon approval by the MESTA Board at its meeting scheduled for February 10th, 2026, with sale proceeds to be deposited into Police Equipment Capital Outlay Account #44-445-5424. Voting yes: Lamar, Shropshire, Brashears, T. Brown, Tramel, S. Brown and Smith. Voting no: none. *Motion passed.*

A5. Discussion and possible action regarding the Mayor signing the interlocal agreement with Mayes County for gravel and asphalt work done at the Police Shooting Range.

Motion was made by Shropshire, second by S. Brown to approve the Mayor to sign the interlocal agreement with Mayes County for gravel and asphalt work done at the Police Shooting Range. Voting yes: Shropshire, Brashears, Tramel, S. Brown, Smith and Lamar. Abstaining, counting as a no vote: T. Brown. Voting no: none. *Motion passed.*

A6. Discussion and possible action regarding an expenditure in the amount of \$13,170.85 to American Legal Publishing Corp. for the final billing of ordinance recodification, from General Dues and Subscriptions Account #02-201-5032.

Motion was made by Shropshire, second by Tramel to approve an expenditure in the amount of \$13,170.85 to American Legal Publishing Corp. for the final billing of ordinance recodification, from General Dues and Subscriptions Account #02-201-5032. Voting yes: Brashears, T. Brown, Tramel, S. Brown, Smith, Lamar and Shropshire. Voting no: none. *Motion passed.*

A7. Discussion and possible action regarding an expenditure in the amount of \$5,419.51 to Pryor Stone Co. for gravel for the Police Shooting Range from Street Sup. Materials Account #14-145-5031.

Motion was made by Shropshire, second by Smith to approve an expenditure in the amount of \$5,419.51 to Pryor Stone Co. for gravel for the Police Shooting Range from Street Sup. Materials Account #14-145-5031. Voting yes: Tramel, S. Brown, Smith, Lamar, Shropshire and Brashears. Abstaining, counting as a no vote: T. Brown. Voting no: none. *Motion passed.*

A8. Discussion and possible action regarding Mayor to sign an agreement with Rainbow Fireworks to secure the date of July 4th, 2026 for the 2026 FreedomFest fireworks show. EDTA funds will be used for the \$1,000.00 deposit required.

Motion was made by Tramel, second by Shropshire to approve Mayor to sign an agreement with Rainbow Fireworks to secure the date of July 4th, 2026 for the 2026 FreedomFest fireworks

show. Voting yes: Tramel, S. Brown, Smith, Lamar, Shropshire, Brashears and T. Brown.
Voting no: none. *Motion passed.*

6. CITY ATTORNEY'S REPORT:

6a. Second reading, discussion and possible approval of an Ordinance of the City of Pryor Creek, Oklahoma granting a non-exclusive permit to Clarity Telecom, LLC (D/B/A Bluepeak) for the construction and operation of a cable system. *Note: A vote of a majority of all the members of the Council shall be required for the final passage of this ordinance pursuant to 11 O.S. § 102. If passed, this ordinance shall be published once in a newspaper of general circulation in the City of Pryor and shall not take effect until thirty (30) days after such publication pursuant to Section 20 and 65 of the Charter of the City of Pryor Creek, Oklahoma.*

Motion was made by S. Brown, second by T. Brown to approve Ordinance #2026-1, an Ordinance of the City of Pryor Creek, Oklahoma granting a non-exclusive permit to Clarity Telecom, LLC (D/B/A Bluepeak) for the construction and operation of a cable system.

Motion was amended by S. Brown, second by T. Brown to approve Ordinance #2026-1, an Ordinance of the City of Pryor Creek, Oklahoma granting a non-exclusive permit to Clarity Telecom, LLC (D/B/A Bluepeak) for the construction and operation of a cable system, amending section 2.2 regarding contract length to allow the contract to be automatically renewed for 10 years, with negotiations to take place before a new contract is signed. Voting yes: S. Brown, Smith, Lamar, Shropshire, Brashears and T. Brown. Voting no: Tramel. *Motion passed.*

Mayor moved back to Addendum item 1.

A1. Possible Executive Session for the purpose of confidential communications with attorney regarding collective bargaining contract negotiations pursuant to 25 O.S. 307(B)(4) & (10).

Motion was made by Shropshire, second by Brashears to enter Executive Session at 7:45 p.m. Voting yes: Smith, Lamar, Shropshire, Brashears, T. Brown, Tramel and S. Brown. Voting no: none. *Motion passed.*

A2. Consider resuming regular session. No action taken during Executive Session.

Motion was made by Brashears, second by Tramel to exit Executive Session at 9:15 p.m. Voting yes: Lamar, Shropshire, Brashears, T. Brown, Tramel, S. Brown and Smith. Voting no: none. *Motion passed.*

8. COMMITTEE REPORTS:

(Items, such as next meeting date, needing to be reported. No open discussions. Any items requiring discussion are to be added to the Mayor's report prior to posting of agenda.)

a. Budget and Personnel

Shropshire reported that the next meeting will be Tuesday, February 10th.

b. Ordinance and Insurance

T. Brown reported that the next meeting will be Tuesday, March 31st. He also stated that the committee may call a special meeting soon.

c. Street and Maintenance

Lamar reported that the next meeting will be Tuesday, February 24th.

9. UNFORESEEABLE BUSINESS.

(ANY MATTER NOT REASONABLY FORESEEN PRIOR TO POSTING OF AGENDA.)

There was no unforeseeable business.

10. ADJOURN.

Motion was made by Tramel, second by S. Brown to adjourn. Voting yes: Shropshire, Brashears, T. Brown, Tramel, S. Brown, Smith and Lamar. Voting no: none.

PRYOR PUBLIC WORKS AUTHORITY

1. CALL TO ORDER.

Meeting was called to order at 9:17 p.m.

2. APPROVE MINUTES OF THE JANUARY 20TH, 2026 MEETING.

Motion was made by Shropshire, second by Brashears to approve the minutes of the January 20th, 2026 meeting. Voting yes: Brashears, T. Brown, Tramel, S. Brown, Smith, Lamar and Shropshire. Voting no: none.

3. APPROVE CLAIMS FOR PURCHASE ORDERS FOR THE PRYOR PUBLIC WORKS AUTHORITY THROUGH FEBRUARY 3RD, 2026.

Motion was made by Shropshire, second by Brashears to approve claims for purchase orders for the Pryor Public Works Authority through February 3rd, 2026. Voting yes: T. Brown, Tramel, S. Brown, Smith, Lamar, Shropshire and Brashears. Voting no: none.

4. UNFORESEEABLE BUSINESS.

(ANY MATTER NOT REASONABLY FORESEEN PRIOR TO POSTING OF AGENDA.)

There was no unforeseeable business.

5. ADJOURN.

Motion was made by Brashears, second by S. Brown to adjourn at 9:18 p.m. Voting yes: Tramel, S. Brown, Smith, Lamar, Shropshire, Brashears and T. Brown. Voting no: none.

MINUTES APPROVED BY MAYOR / P.P.W.A. CHAIRMAN ZAC DOYLE

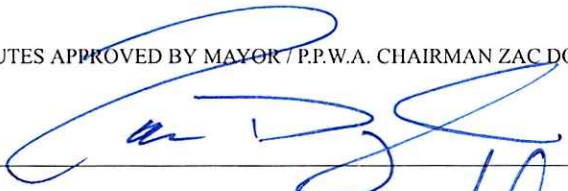

MINUTES WRITTEN BY CITY CLERK HANNAH MORKIS

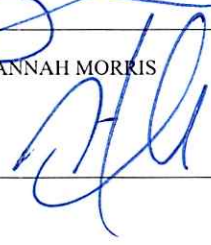





February 1, 2026

City of Pryor

We are pleased to confirm our understanding of the services we are to provide for City of Pryor for the year ended June 30, 2025.

Audit Scope and Objectives

We will audit the financial statements of governmental activities, the business-type activities, the aggregate discretely presented component units, each major fund, and the aggregate remaining fund information, including the disclosures, which collectively comprise the basic financial statements, of City of Pryor as of and for the year ended June 30, 2025.

Accounting standards generally accepted in the United States of America (GAAP) provide for certain required supplementary information (RSI), such as management's discussion and analysis (MD&A), to supplement City of Pryor's basic financial statements. Such information, although not a part of the basic financial statements, is required by the Governmental Accounting Standards Board who considers it to be an essential part of financial reporting for placing the basic financial statements in an appropriate operational, economic, or historical context. As part of our engagement, we will apply certain limited procedures to City of Pryor's RSI in accordance with auditing standards generally accepted in the United States of America (GAAS). These limited procedures will consist of inquiries of management regarding the methods of preparing the information and comparing the information for consistency with management's responses to our inquiries, the basic financial statements, and other knowledge we obtained during our audit of the basic financial statements. We will not express an opinion or provide any assurance on the information because the limited procedures do not provide us with sufficient appropriate evidence to express an opinion or provide any assurance. The following RSI is required by GAAP and will be subjected to certain limited procedures, but will not be audited:

1) Management's Discussion and Analysis.

The objectives of our audit are to obtain reasonable assurance about whether the financial statements as a whole are free from material misstatement, whether due to fraud or error, and issue an auditor's report that includes our opinions about whether your financial statements are fairly presented, in all material respects, in conformity with GAAP, and report on the fairness of the supplementary information referred to in the second paragraph when considered in relation to the financial statements as a whole. Reasonable assurance is a high level of assurance but is not absolute assurance and therefore is not a guarantee that an audit conducted in accordance with GAAS and *Government Auditing Standards* will always detect a material misstatement when it exists. Misstatements, including omissions, can arise from fraud or error and are considered material if there is a substantial likelihood that, individually or in the aggregate, they would influence the judgment of a reasonable user made based on the financial statements.

HOOD & ASSOCIATES CPAs, P.C.

AUDIT.HOODCPAS.COM

The objectives also include reporting on internal control over financial reporting and compliance with provisions of laws, regulations, contracts, and award agreements, noncompliance with which could have a material effect on the financial statements in accordance with *Government Auditing Standards*.

Auditor's Responsibilities for the Audit of the Financial Statements

We will conduct our audit in accordance with GAAS and the standards for financial audits contained in *Government Auditing Standards*, issued by the Comptroller General of the United States, and will include tests of your accounting records of City of Pryor and other procedures we consider necessary to enable us to express such opinions. As part of an audit in accordance with GAAS and *Government Auditing Standards*, we exercise professional judgment and maintain professional skepticism throughout the audit.

We will evaluate the appropriateness of accounting policies used and the reasonableness of significant accounting estimates made by management. We will also evaluate the overall presentation of the financial statements, including the disclosures, and determine whether the financial statements represent the underlying transactions and events in a manner that achieves fair presentation. We will plan and perform the audit to obtain reasonable assurance about whether the financial statements are free of material misstatement, whether from (1) errors, (2) fraudulent financial reporting, (3) misappropriation of assets, or (4) violations of laws or governmental regulations that are attributable to the government or to acts by management or employees acting on behalf of the government. Because the determination of waste and abuse is subjective, *Government Auditing Standards* do not expect auditors to perform specific procedures to detect waste or abuse in financial audits nor do they expect auditors to provide reasonable assurance of detecting waste or abuse.

Because of the inherent limitations of an audit, combined with the inherent limitations of internal control, and because we will not perform a detailed examination of all transactions, there is an unavoidable risk that some material misstatements may not be detected by us, even though the audit is properly planned and performed in accordance with GAAS and *Government Auditing Standards*. In addition, an audit is not designed to detect immaterial misstatements or violations of laws or governmental regulations that do not have a direct and material effect on the financial statements. However, we will inform the appropriate level of management of any material errors, fraudulent financial reporting, or misappropriation of assets that comes to our attention. We will also inform the appropriate level of management of any violations of laws or governmental regulations that come to our attention, unless clearly inconsequential. Our responsibility as auditors is limited to the period covered by our audit and does not extend to any later periods for which we are not engaged as auditors.

We will also conclude, based on the audit evidence obtained, whether there are conditions or events, considered in the aggregate, that raise substantial doubt about the government's ability to continue as a going concern for a reasonable period of time.

Our procedures will include tests of documentary evidence supporting the transactions recorded in the accounts, tests of the physical existence of inventories, and direct confirmation of receivables and certain assets and liabilities by correspondence with selected customers, creditors, and financial institutions. We will also request written representations from your attorneys as part of the engagement.

We have identified the following significant risk(s) of material misstatement as part of our audit planning:

Management Override of Controls

Improper Revenue Recognition

We may, from time to time and depending on the circumstances, use third-party service providers in serving your account. We may share confidential information about you with these service providers but remain committed to maintaining the confidentiality and security of your information. Accordingly, we maintain internal policies, procedures, and safeguards to protect the confidentiality of your personal information. In addition, we will secure confidentiality agreements with all service providers to maintain the confidentiality of your information and we will take reasonable precautions to determine that they have appropriate procedures in place to prevent the unauthorized release of your confidential information to others. In the event that we are unable to secure an appropriate

confidentiality agreement, you will be asked to provide your consent prior to the sharing of your confidential information with the third-party service provider. Furthermore, we will remain responsible for the work provided by any such third-party service providers.

Our audit of financial statements does not relieve you of your responsibilities.

Audit Procedures—Internal Control

We will obtain an understanding of the government and its environment, including internal control relevant to the audit, sufficient to identify and assess the risks of material misstatement of the financial statements, whether due to error or fraud, and to design and perform audit procedures responsive to those risks and obtain evidence that is sufficient and appropriate to provide a basis for our opinions. Tests of controls may be performed to test the effectiveness of certain controls that we consider relevant to preventing and detecting errors and fraud that are material to the financial statements and to preventing and detecting misstatements resulting from illegal acts and other noncompliance matters that have a direct and material effect on the financial statements. Our tests, if performed, will be less in scope than would be necessary to render an opinion on internal control and, accordingly, no opinion will be expressed in our report on internal control issued pursuant to *Government Auditing Standards*. The risk of not detecting a material misstatement resulting from fraud is higher than for one resulting from error, as fraud may involve collusion, forgery, intentional omissions, misrepresentation, or the override of internal control. An audit is not designed to provide assurance on internal control or to identify significant deficiencies or material weaknesses. Accordingly, we will express no such opinion. However, during the audit, we will communicate to management and those charged with governance internal control related matters that are required to be communicated under AICPA professional standards and *Government Auditing Standards*.

Audit Procedures—Compliance

As part of obtaining reasonable assurance about whether the financial statements are free of material misstatement, we will perform tests of City of Pryor's compliance with the provisions of applicable laws, regulations, contracts, agreements, and grants. However, the objective of our audit will not be to provide an opinion on overall compliance and we will not express such an opinion in our report on compliance issued pursuant to *Government Auditing Standards*.

Responsibilities of Management for the Financial Statements

Our audit will be conducted on the basis that you acknowledge and understand your responsibility for designing, implementing, establishing, and maintaining effective internal controls relevant to the preparation and fair presentation of financial statements that are free from material misstatement, whether due to fraud or error, and for evaluating and monitoring ongoing activities to help ensure that appropriate goals and objectives are met; following laws and regulations; and ensuring that management and financial information is reliable and properly reported. Management is also responsible for implementing systems designed to achieve compliance with applicable laws, regulations, contracts, and grant agreements. You are also responsible for the selection and application of accounting principles, for the preparation and fair presentation of the financial statements and all accompanying information in conformity with accounting principles generally accepted in the United States of America, and for compliance with applicable laws and regulations and the provisions of contracts and grant agreements.

Management is responsible for making drafts of financial statements, all financial records, and related information available to us and for the accuracy and completeness of that information (including information from outside of the general and subsidiary ledgers). You are also responsible for providing us with (1) access to all information of which you are aware that is relevant to the preparation and fair presentation of the financial statements, such as records, documentation, identification of all related parties and all related-party relationships and transactions, and other matters; (2) additional information that we may request for the purpose of the audit; and (3) unrestricted access to persons within the government from whom we determine it necessary to obtain audit evidence. At the conclusion of our audit, we will require certain written representations from you about your responsibilities for the financial statements; compliance with laws, regulations, contracts, and grant agreements; and other responsibilities required by GAAS and *Government Auditing Standards*.

Your responsibilities include adjusting the financial statements to correct material misstatements and for confirming to us in the written representation letter that the effects of any uncorrected misstatements aggregated by us during the current engagement and pertaining to the latest period presented are immaterial, both individually and in the aggregate, to the financial statements of each opinion unit taken as a whole.

You are responsible for the design and implementation of programs and controls to prevent and detect fraud, and for informing us about all known or suspected fraud affecting the government involving (1) management, (2) employees who have significant roles in internal control, and (3) others where the fraud could have a material effect on the financial statements. Your responsibilities include informing us of your knowledge of any allegations of fraud or suspected fraud affecting the government received in communications from employees, former employees, grantors, regulators, or others. In addition, you are responsible for identifying and ensuring that the government complies with applicable laws, regulations, contracts, agreements, and grants and for taking timely and appropriate steps to remedy fraud and noncompliance with provisions of laws, regulations, or contracts or grant agreements that we report.

You are responsible for the preparation of the supplementary information, which we have been engaged to report on, in conformity with accounting principles generally accepted in the United States of America (GAAP). You agree to include our report on the supplementary information in any document that contains, and indicates that we have reported on, the supplementary information. You also agree to [include the audited financial statements with any presentation of the supplementary information that includes our report thereon OR make the audited financial statements readily available to users of the supplementary information no later than the date the supplementary information is issued with our report thereon]. Your responsibilities include acknowledging to us in the written representation letter that (1) you are responsible for presentation of the supplementary information in accordance with GAAP; (2) you believe the supplementary information, including its form and content, is fairly presented in accordance with GAAP; (3) the methods of measurement or presentation have not changed from those used in the prior period (or, if they have changed, the reasons for such changes); and (4) you have disclosed to us any significant assumptions or interpretations underlying the measurement or presentation of the supplementary information.

Management is responsible for establishing and maintaining a process for tracking the status of audit findings and recommendations. Management is also responsible for identifying and providing report copies of previous financial audits, attestation engagements, performance audits or other studies related to the objectives discussed in the Audit Scope and Objectives section of this letter. This responsibility includes relaying to us corrective actions taken to address significant findings and recommendations resulting from those audits, attestation engagements, performance audits, or other studies. You are also responsible for providing management's views on our current findings, conclusions, and recommendations, as well as your planned corrective actions, for the report, and for the timing and format for providing that information.

Engagement Administration, Fees, and Other

We understand that your employees will prepare all cash, accounts receivable, or other confirmations we request and will locate any documents selected by us for testing.

We will provide copies of our reports to shareholders; however, management is responsible for distribution of the reports and the financial statements. Unless restricted by law or regulation, or containing privileged and confidential information, copies of our reports are to be made available for public inspection.

The audit documentation for this engagement is the property of Hood & Associates CPAs, PC and constitutes confidential information. However, subject to applicable laws and regulations, audit documentation and appropriate individuals will be made available upon request and in a timely manner to a Company designee, a federal agency providing direct or indirect funding, or the U.S. Government Accountability Office for the purposes of a quality review of the audit, to resolve audit findings, or to carry out oversight responsibilities. We will notify you of any such request. If requested, access to such audit documentation will be provided under the supervision of Hood & Associates CPAs, PC personnel. Furthermore, upon request, we may provide copies of selected audit documentation to the aforementioned parties. These parties may intend or decide to distribute the copies or information contained therein to others, including other governmental agencies.

The audit documentation for this engagement will be retained for a minimum of five years after the report release date or for any additional period requested by the Oklahoma State Auditor and Inspector General, Oversight Agency for Audit, or Pass-through Entity. If we are aware that a federal awarding agency, pass-through entity, or auditee is contesting an audit finding, we will contact the party(ies) contesting the audit finding for guidance prior to destroying the audit documentation.

Violet Kirkendall is the engagement partner and is responsible for supervising the engagement and signing the reports or authorizing another individual to sign them. We expect to begin our audit as soon after June 30, 2025 as records are made available to us.

We have developed an audit plan and budget for this engagement based on our limited understanding of your financial records and your reporting requirements. Our fee for this engagement is based on our standard hourly rates. Our standard hourly rates vary according to the degree of responsibility involved and the experience level of the personnel assigned to your audit. The budget for this engagement at standard audit rates is as follows:

- Audit of financial statements provided.....\$20,500

In accordance with our firm policies, work may be suspended if your account becomes 30 days or more overdue and may not be resumed until your account is paid in full. If we elect to terminate our services for nonpayment, our engagement will be deemed to have been completed upon written notification of termination, even if we have not completed our report(s). You will be obligated to compensate us for all time expended and to reimburse us for all out-of-pocket costs through the date of termination. The above fee is based on anticipated cooperation from your personnel and the assumption that unexpected circumstances will not be encountered during the engagement. If significant additional time is necessary, we will keep you informed of any problems we encounter and our fees will be adjusted accordingly.

Reporting

We will issue a written report upon completion of our audit of City of Pryor’s financial statements. Our report will be addressed to management of City of Pryor. Circumstances may arise in which our report may differ from its expected form and content based on the results of our audit. Depending on the nature of these circumstances, it may be necessary for us to modify our opinions, add a separate section, or add an emphasis-of-matter or other-matter paragraph to our auditor’s report, or if necessary, withdraw from this engagement. If our opinions are other than unmodified, we will discuss the reasons with you in advance. If, for any reason, we are unable to complete the audit or are unable to form or have not formed opinions, we may decline to express opinions or issue reports, or we may withdraw from this engagement.

We will also provide a report (that does not include an opinion) on internal control related to the financial statements and compliance with the provisions of laws, regulations, contracts, and grant agreements, noncompliance with which could have a material effect on the financial statements as required by *Government Auditing Standards*. The report on internal control and on compliance and other matters will state (1) that the purpose of the report is solely to describe the scope of testing of internal control and compliance, and the results of that testing, and not to provide an opinion on the effectiveness of the entity’s internal control on compliance, and (2) that the report is an integral part of an audit performed in accordance with *Government Auditing Standards* in considering the entity’s internal control and compliance. The report will also state that the report is not suitable for any other purpose. If during our audit we become aware that City of Pryor is subject to an audit requirement that is not encompassed in the terms of this engagement, we will communicate to management and those charged with governance that an audit in accordance with U.S. generally accepted auditing standards and the standards for financial audits contained in *Government Auditing Standards* may not satisfy the relevant legal, regulatory, or contractual requirements.

We appreciate the opportunity to be of service to you and believe this letter accurately summarizes the significant terms of our engagement. If you have any questions, please let us know. If you agree with the terms of our engagement as described in this letter, please sign the attached copy and return it to us.

Very truly yours,

Hood & Associates CPAs, PC

RESPONSE:

This letter correctly sets forth the understanding of City of Pryor.

Management signature: _____

Title: _____

Date: _____



3650 S. Boulevard • Edmond, OK 73013 • omag.org
 405.657.1400 • 800.234.9461 • FAX 405.657.1401

Date of Invoice: 2/15/2026

INVOICE

Mail To: RCI Insurance City of Pryor Creek	Insured: City of Pryor Creek Policy No.: PRO1400033010 Policy Type: Property Effective Date: 7/1/2025 Expiration Date: 7/1/2026
---	--

Inst. No.	Date	Transaction Type	Amount
1	7/1/2025	Renewal	\$41,398.25
	6/23/2025	Payment	-\$41,398.25
2	10/1/2025	Installment	\$41,398.25
	10/23/2025	Payment	-\$41,398.25
3	1/1/2026	Installment	\$41,398.25
	12/3/2025	Payment	-\$41,398.25
4	4/1/2026	Installment	\$41,398.25
			Current Amount Due
Total Policy Balance Before Payment: \$41,398.25			Payment Due By
			4/1/2026

**Thank you for your business. If you have questions about your account,
 please call 1-800-234-9461 or 405-657-1400.**

If not paid within 45 days of due date, policy will be cancelled.

If you are interested in being able to make this payment via ACH, please contact Renea Harris at (405) 657-1426.

Detach along the perforation above. Keep top portion for your records. Return bottom portion with your remittance.

Policy No.: PRO1400033010 Insured: City of Pryor Creek	Amount Due: \$41,398.25 Payment Due By: 4/1/2026
---	---

PLEASE REMIT PAYMENT TO:

OMAG
 P.O. Box 3091
 Edmond, OK 73083



3650 S. Boulevard • Edmond, OK 73013 • omag.org
 405.657.1400 • 800.234.9461 • FAX 405.657.1401

Date of Invoice: 2/15/2026

INVOICE

Mail To: RCI Insurance City of Pryor Creek	Insured: City of Pryor Creek Policy No.: GLA1400017010 Policy Type: General Liability/Auto Effective Date: 7/1/2025 Expiration Date: 7/1/2026
---	--

Inst. No.	Date	Transaction Type	Amount	
1	7/1/2025	Renewal	\$30,201.00	
	6/23/2025	Payment	-\$30,201.00	
	7/17/2025	Endorsement - Additional Premium	\$979.00	
2	10/1/2025	Installment	\$30,201.00	
	8/22/2025	Endorsement - Returned Premium	-\$1,318.00	
	9/9/2025	Payment	-\$979.00	
	9/9/2025	Payment	-\$30,201.00	
3	9/16/2025	Endorsement - Additional Premium	\$1,519.00	
	1/1/2026	Installment	\$30,201.00	
	12/3/2025	Payment	\$1,318.00	
	12/3/2025	Payment	-\$1,519.00	
	12/3/2025	Payment	-\$30,201.00	
	1/23/2026	Endorsement - Additional Premium	\$6.00	
	1/23/2026	Waived Premium	-\$6.00	
4	1/26/2026	Endorsement - Returned Premium	-\$5.00	
	2/6/2026	Endorsement - Additional Premium	\$69.00	
	4/1/2026	Installment	\$30,201.00	
			Current Amount Due	\$30,265.00
Total Policy Balance Before Payment: \$30,265.00			Payment Due By	4/1/2026

**Thank you for your business. If you have questions about your account,
 please call 1-800-234-9461 or 405-657-1426.**

If not paid within 45 days of due date, policy will be cancelled.

If you are interested in making this payment via ACH, please contact Renea Harris at (405) 657-1426.

Detach along the perforation above. Keep top portion for your records. Return bottom portion with your remittance.

Policy No.: GLA1400017010 Insured: City of Pryor Creek	Amount Due: \$30,265.00 Payment Due By: 4/1/2026
---	---

PLEASE REMIT PAYMENT TO:

OMAG
 P.O. Box 3091
 Edmond, OK 73083

City Council Item Report

City of Pryor Creek, Oklahoma

Meeting Date:
March 3, 2026

Prepared By:
Jae Standingwater , Mayor's Secretary

Summary:
This upgrade to the Council Chamber A/V system enables the clerk or secretary to control the stream, microphones, and camera angles from the secretary's desk. This will greatly improve meeting operations, professionalism of the recordings, and public transparency through effective communication.

Background:
Backward Audio is the same company that installed the original A/V system in the Council Chambers, as well as the recent upgrades.

Recommendation:

Fiscal Impact:

- Attachments:**
1. Stream Deck Quote

City Council Item Report

City of Pryor Creek, Oklahoma

Meeting Date:
March 3, 2026

Prepared By:
Kevin Tramel

Summary:

The Pryor Police Dept has been approved for a JAG Grant in the amount of \$9,999.96 for the purchase of laptops. Once the funds have been received they will be deposited back in the donations and grants revenue account #02-000-4251 where it can be moved accordingly back to the Police Misc. Cherokee Nation Donation Account #96-965-5502.

Background:

Recommendation:

Fiscal Impact:

Attachments:

1. Dell Technologies Quote - Kevin Tramel



Your quote is ready for purchase.

Complete the purchase of your personalized quote through our secure online checkout before the quote expires on **Mar. 09, 2026**.

You can download a copy of this quote during checkout.

[Place your order](#)

Quote Name:	Laptops and Power Supplies Qty 6	Sales Rep	Lance Glover
Quote No.	3000199504890.1	Phone	4563355
Total	\$18,517.68	Email	Lance.Glover@Dell.com
Customer #	70361194	Billing To	ACCOUNTS PAYABLE
Quoted On	Feb. 23, 2026		CITY OF PRYOR CREEK
Expires by	Mar. 09, 2026		P O BOX 1167
	OMNIA-National		6 NORTH ADAIR
Contract Name	Cooperative Purchasing Alliance (NCPA)		PRYOR, OK 74362
Contract Code	C000001019611		
Customer Agreement #	NCPA 01-143		
Deal ID	30704585		

Message from your Sales Rep

Please use the Order button to securely place the order with your preferred payment method online. You may contact your Dell sales team if you have any questions. Thank you for shopping with Dell.

Regards,
Lance Glover

Shipping Group

Shipping To	Shipping Method
KEVIN TRAMEL CITY OF PRYOR CREEK 504 E GRAHAM AVE PRYOR CREEK POLICE DEPT PRYOR, OK 74361 (918) 825-1212	Standard Delivery

Product	Unit Price	Quantity	Subtotal
Havis Lind 120W Power Supply	\$232.79	6	\$1,396.74
Dell Pro Rugged 14 RB14250	\$2,853.49	6	\$17,120.94

Subtotal:	\$18,517.68
Shipping:	\$0.00
Non-Taxable Amount:	\$18,517.68
Taxable Amount:	\$0.00
Estimated Tax:	\$0.00

Total:	\$18,517.68
---------------	--------------------

Shipping Group Details

Shipping To

KEVIN TRAMEL
CITY OF PRYOR CREEK
504 E GRAHAM AVE
PRYOR CREEK POLICE DEPT
PRYOR, OK 74361
(918) 825-1212

Shipping Method

Standard Delivery

Havis Lind 120W Power Supply

Estimated delivery if purchased today:
Apr. 09, 2026
Contract # C000001019611
Customer Agreement # NCPA 01-143

Unit Price	Quantity	Subtotal
\$232.79	6	\$1,396.74

Description

SKU

Unit Price	Quantity	Subtotal
------------	----------	----------

Havis Lind 120W Power Supply

AD163121

-	6	-
---	---	---

Unit Price	Quantity	Subtotal
\$2,853.49	6	\$17,120.94

Dell Pro Rugged 14 RB14250

Estimated delivery if purchased today:
Mar. 10, 2026
Contract # C000001019611
Customer Agreement # NCPA 01-143

Description

SKU

Unit Price	Quantity	Subtotal
------------	----------	----------

Dell Pro Rugged, RB14250 XCTO

210-BNNG

-	6	-
---	---	---

Intel R Core TM Ultra 5 125U (12 MB cache, 12 cores, up to 4.30 GHz, 15W)

379-BFTK

-	6	-
---	---	---

Windows 11 Pro

619-BBQD

-	6	-
---	---	---

Intel R Core TM Ultra 5 125U (12 MB cache, 12 cores, up to 4.30 GHz, 15W)

338-CQVF

-	6	-
---	---	---

16GB: 2 X 8 GB, DDR5, 5600, Non-ECC, SoDIMM

370-BCGC

-	6	-
---	---	---

256GB PCIe NVMe 2230 SSD

400-BSFM

-	6	-
---	---	---

14" Touch, FHD 1920x1080, 60Hz, WVA, Anti-Glare, 1100nit, Low Blue Light, IR camera, Passive Pen

391-BJNQ

-	6	-
---	---	---

FHD HDR IR Camera + Microphone, Touch Display, WLAN/WWAN/GPS antenna

319-BBLD

-	6	-
---	---	---

5G Qualcomm(R) Snapdragon(TM) X62 Global 5G (DW5932e), eSIM capable, AT&T

556-BFRR

-	6	-
---	---	---

Intel® Wi-Fi 6E AX211, 2x2, 802.11ax, MU-MIMO, Bluetooth® 5.3 wireless card

555-BLHY

-	6	-
---	---	---

Wireless Intel AX211 WLAN Driver

555-BLJD

-	6	-
---	---	---

Core Ultra 5 non-vPro CPU Label, Gen 14th

389-FJFB

-	6	-
---	---	---

English US Rugged RGB Single Point backlit Copilot key keyboard

583-BMJG

-	6	-
---	---	---

Full Security: Fingerprint reader, Contacted Smartcard reader, NFC Contactless Smartcard reader

346-BLBH

-	6	-
---	---	---

65W AC adapter, USB Type-C

492-BDTG

-	6	-
---	---	---

E4 C5 black Power Cord 1M, US

470-BCRH

-	6	-
---	---	---

Primary 3 Cell 53.5 Whr ExpressCharge Capable Battery

389-FJFG

-	6	-
---	---	---

Battery Airbay Cover

325-BFXD

-	6	-
---	---	---

Service and Support Guide MUI for DAO (English, French, Multi)	340-DSGW	-	6	-
Quick setup guide, WW	340-DRXV	-	6	-
No Resource USB Media	430-XYPF	-	6	-
ME Disable - Manageability	631-BBYT	-	6	-
ENERGY STAR Qualified	387-BBLW	-	6	-
EPEAT Gold with Climate+	379-BFWZ	-	6	-
Dedicated u-blox NEO-M9N GPS Card	540-BFLV	-	6	-
Mix Shipment, Dell Pro Rugged 14 RB14250	340-DSCG	-	6	-
Standard Shipment, VS	800-BBZV	-	6	-
English, French, Spanish, Brazilian Portuguese	619-BBPD	-	6	-
No additional TBT-4/Type-C port with FPR	325-BFXS	-	6	-
Additional rear USB 3.2 Type-A port	590-TFPW	-	6	-
Intel Responsiveness Technologies Driver	409-BCYL	-	6	-
Rigid Handle	750-BBMM	-	6	-
Custom Configuration	817-BBBB	-	6	-
Docking POGO connector with Antenna Passthru, WLAN+WWAN+GPS antenna	452-BDZH	-	6	-
ProSupport Plus: Next Business Day Onsite, 3 Years	713-0299	-	6	-
Dell Limited Hardware Warranty Initial Year	713-0305	-	6	-
ProSupport Plus: Accidental Damage Service, 3 Years	713-0317	-	6	-
ProSupport Plus: Keep Your Hard Drive, 3 Years	713-0318	-	6	-
ProSupport Plus: 7X24 Technical Support, 3 Years	713-0339	-	6	-
Thank you for choosing Dell ProSupport Plus. For tech support, visit www.dell.com/contactdell or call 1-866-516-3115	997-8367	-	6	-
Activate Your Microsoft 365 For A 30 Day Trial	658-BCSB	-	6	-
Dell Additional Software	634-CVYV	-	6	-
No Additional Software	658-BFOH	-	6	-

Subtotal:	\$18,517.68
Shipping:	\$0.00
Estimated Tax:	\$0.00
Total:	\$18,517.68

Important Notes

Terms of Sale

This Quote will, if Customer issues a purchase order for the quoted items that is accepted by Supplier, constitute a contract between the entity issuing this Quote ("Supplier") and the entity to whom this Quote was issued ("Customer"). Unless otherwise stated herein, pricing is valid for Fourteen days from the date of this Quote. All products, pricing, and other information are based on the latest information available and are subject to change for any reason, including but not limited to tariffs imposed by government authorities, shortages in materials or resources, increase in the cost of manufacturing or other factors beyond Supplier's reasonable control. If such changes occur, pricing may be adjusted or purchase orders may be cancelled by Supplier, even after an order has been placed. Supplier also reserves the right to cancel this Quote and Customer purchase orders arising from pricing errors and/or customer changes to Supplier's planned delivery date. Taxes and/or freight charges listed on this Quote are only estimates. The final amounts shall be stated on the relevant invoice. Additional freight charges will be applied if Customer requests expedited shipping. Please indicate any tax exemption status on your purchase order and send your tax exemption certificate to Tax_Department@dell.com or ARSalesTax@emc.com, as applicable.

Governing Terms: This Quote is subject to: (a) a separate written agreement between Customer or Customer's affiliate and Supplier or a Supplier's affiliate to the extent that it expressly applies to the products and/or services in this Quote or, to the extent there is no such agreement, to the applicable set of Dell's Terms of Sale (available at www.dell.com/terms or www.dell.com/oemterms), or for cloud/as-a-Service offerings, the applicable cloud terms of service (identified on the Offer Specific Terms referenced below); and (b) the terms referenced herein (collectively, the "Governing Terms"). Different Governing Terms may apply to different products and services on this Quote. The Governing Terms apply to the exclusion of all terms and conditions incorporated in or referred to in any documentation submitted by Customer to Supplier.

Supplier Software Licenses and Services Descriptions: Customer's use of any Supplier software is subject to the license terms accompanying the software, or in the absence of accompanying terms, the applicable terms posted on www.Dell.com/eula. Descriptions and terms for Supplier-branded standard services are stated at www.dell.com/servicecontracts/global or for certain infrastructure products at www.dell.com/en-us/customer-services/product-warranty-and-service-descriptions.htm.

Offer-Specific, Third Party and Program Specific Terms: Customer's use of third-party software is subject to the license terms that accompany the software. Certain Supplier-branded and third-party products and services listed on this Quote are subject to additional, specific terms stated on www.dell.com/offeringsspecificterms ("Offer Specific Terms").

In case of Resale only: Should Customer procure any products or services for resale, whether on standalone basis or as part of a solution, Customer shall include the applicable software license terms, services terms, and/or offer-specific terms in a written agreement with the end-user and provide written evidence of doing so upon receipt of request from Supplier.

In case of Financing only: If Customer intends to enter into a financing arrangement ("Financing Agreement") for the products and/or services on this Quote with Dell Financial Services LLC or other funding source pre-approved by Supplier ("FS"), Customer may issue its purchase order to Supplier or to FS. If issued to FS, Supplier will fulfill and invoice FS upon confirmation that: (a) FS intends to enter into a Financing Agreement with Customer for this order; and (b) FS agrees to procure these items from Supplier. Notwithstanding the Financing Agreement, Customer's use (and Customer's resale of and the end-user's use) of these items in the order is subject to the applicable governing agreement between Customer and Supplier, except that title shall transfer from Supplier to FS instead of to Customer. If FS notifies Supplier after shipment that Customer is no longer pursuing a Financing Agreement for these items, or if Customer fails to enter into such Financing Agreement within 120 days after shipment by Supplier, Customer shall promptly pay the Supplier invoice amounts directly to Supplier.

Customer represents that this transaction does not involve: (a) use of U.S. Government funds; (b) use by or resale to the U.S. Government; or (c) maintenance and support of the product(s) listed in this document within classified spaces. Customer further represents that this transaction does not require Supplier's compliance with any statute, regulation or information technology standard applicable to a U.S. Government procurement.

For certain products shipped to end users in California, a State Environmental Fee will be applied to Customer's invoice. Supplier encourages customers to dispose of electronic equipment properly.

Electronically linked terms and descriptions are available in hard copy upon request.



PRYOR, CITY OF
Copy of APX N30, with AES
02/26/2026

02/26/2026

PRYOR, CITY OF
PO BOX 1167
PRYOR, OK 74362

RE: Motorola Quote for Copy of APX N30, with AES

Dear Jeremy Cantrell,

Motorola Solutions is pleased to present PRYOR, CITY OF with this quote for quality communications equipment and services. The development of this quote provided us the opportunity to evaluate your requirements and propose a solution to best fulfill your communications needs.

This information is provided to assist you in your evaluation process. Our goal is to provide PRYOR, CITY OF with the best products and services available in the communications industry. Please direct any questions to Scott Wilson at scott@muskogeecomm.org.

We thank you for the opportunity to provide you with premier communications and look forward to your review and feedback regarding this quote.

Sincerely,

Scott Wilson

Motorola Solutions Manufacturer's Representative

Billing Address:
 PRYOR, CITY OF
 PO BOX 1167
 PRYOR, OK 74362
 US

Quote Date:02/26/2026
 Expiration Date:04/27/2026
 Quote Created By:
 Scott Wilson
 scott@muskogeecomm.org

End Customer:
 PRYOR, CITY OF
 Jeremy Cantrell
 cantrellj@pryorcreek.org

Contract: 37435 - OMES, OK SW1053M
 AGREEMENT: STATE OF OKLAHOMA

Summary:

Any sales transaction resulting from Motorola's quote is based on and subject to the applicable Motorola Standard Terms and Conditions, notwithstanding terms and conditions on purchase orders or other Customer ordering documents. Motorola Standard Terms and Conditions are found at www.motorolasolutions.com/product-terms.

Line #	Item Number	Description	Qty	Term	List Price	Sale Price	Ext. Sale Price
	APX™ N30	APX N30					
1	H15UCF9PW6AN	PORTABLE RADIO APX N30 7/800 MODEL 2	6		\$2,635.00	\$1,623.55	\$9,741.30
1a	BD00032AA	ADD: ESSENTIAL CORE BUNDLE	6		\$2,401.00	\$1,752.73	\$10,516.38
1b	QA00580BA	ADD: TDMA OPERATION	6		\$0.00	\$0.00	\$0.00
1c	QA02756AB	SOFTWARE LICENSE ENH: 3600 OR 9600 TRUNKING BAUD SINGLE SYSTEM	6		\$0.00	\$0.00	\$0.00
1d	G996AU	ADD: PROGRAMMING OVER P25 (OTAP)	6		\$0.00	\$0.00	\$0.00
1e	QA09001AM	ADD: WIFI CAPABILITY	6		\$0.00	\$0.00	\$0.00
1f	QA09007AD	ADD: OUT OF THE BOX WIFI PROVISIONING	6		\$0.00	\$0.00	\$0.00
1g	Q387CB	ADD: MULTICAST VOTING SCAN	6		\$0.00	\$0.00	\$0.00
1h	QA08715AA	ADD: BASIC VOICE CONTROL	6		\$0.00	\$0.00	\$0.00
1i	QA03399AK	ADD: ENHANCED DATA	6		\$0.00	\$0.00	\$0.00
1j	QA00982AH	ADD: SITE SELECTABLE ALERT FOR P25 TRUNKING	6		\$0.00	\$0.00	\$0.00



Any sales transaction following Motorola's quote is based on and subject to the terms and conditions of the valid and executed written contract between Customer and Motorola (the "Underlying Agreement") that authorizes Customer to purchase equipment and/or services or license software (collectively "Products"). If no Underlying Agreement exists between Motorola and Customer, then Motorola's Standard Terms of Use and Motorola's Standard Terms and Conditions of Sales and Supply shall govern the purchase of the Products.
 Motorola Solutions, Inc.: 500 West Monroe, United States - 60661 ~ #: 36-1115800

Line #	Item Number	Description	Qty	Term	List Price	Sale Price	Ext. Sale Price
1k	QA07682AC	ADD: SMARTCONNECT N30/N50	6		\$0.00	\$0.00	\$0.00
1l	BD00033AA	ADD: ESSENTIAL SECURITY BUNDLE	6		\$667.00	\$486.91	\$2,921.46
1m	QA01767BL	ADD: P25 LINK LAYER AUTHENTICATION	6		\$0.00	\$0.00	\$0.00
1n	H869DB	SOFTWARE LICENSE ENH: MULTIKEY	6		\$0.00	\$0.00	\$0.00
1o	QA06653AA	SOFTWARE LICENSE ENH: AES 256 SW ENCRYPTION AND ADP	6		\$0.00	\$0.00	\$0.00
1p	QA09113AA	ADD: BASELINE RELEASE SW	6		\$0.00	\$0.00	\$0.00
1q	QA08853AA	ADD: CPS ENABLEMENT	6		\$0.00	\$0.00	\$0.00
2	PMMN4141ATAA	XVP750 REMOTE SPEAKER MICROPHONE WITH CHANNEL KNOB, FOR APX N RADIOS TAA	6		\$543.13	\$396.48	\$2,378.88
3	PMPN4820B	CHR DESKTOP SINGLE UNIT IMPRES 2 EXT PS US/NA	6		\$91.71	\$66.95	\$401.70
4	PSV01S03059A	APX NEXT PROVISIONING WITH CPS	1		\$0.00	\$0.00	\$0.00
5	LSV01S03084A	APX N50/30 DMS ESSENTIAL	6	5 YEARS	\$264.00	\$264.00	\$1,584.00
6	SSV01S01663A	APX SMART CONNECT	6	5 YEARS	\$480.00	\$480.00	\$2,880.00

Grand Total
\$30,423.72(USD)
Notes:

- The Pricing Summary is a breakdown of costs and does not reflect the frequency at which you will be invoiced.

Motorola's quote (Quote Number: _____ Dated: _____) is based on and subject to the terms and conditions of the valid and executed written contract between Customer and Motorola (the "Underlying Agreement") that authorizes Customer to purchase equipment and/or services or license software (collectively "Products"). If no Underlying Agreement exists between Motorola and Customer, then the following Motorola's Standard Terms of use and Purchase Terms and Conditions govern the purchase of the Products which is found at <http://www.motorolasolutions.com/product-terms>.

The Parties hereby enter into this Agreement as of the Effective Date.



Motorola Solutions, Inc.

Customer

By: _____

By: _____

Name: _____

Name: _____

Title: _____

Title: _____

Date: _____

Date: _____

- **Promotions:**

The following promotion(s) have been applied:

* Line #1 - APX N SERIES TRADE-IN PROMO available from 01/27/2026 to 03/17/2026

- Unless otherwise noted, this quote excludes sales tax or other applicable taxes (such as Goods and Services Tax, sales tax, Value Added Tax and other taxes of a similar nature). Any tax the customer is subject to will be added to invoices.



Line #	Item Number	Parametric Data
1q	QA08853AA	TEMAILAR = scott@muskogeecomm.org,SYSTEMID = 2348
4	PSV01S03059A	TEMAILAR = scott@muskogeecomm.org,CUSTNAME = Scott, Wilson,SYSTEMID = 2348
6	SSV01S01663A	EMAILADR = scott@muskogeecomm.org



APX N30 PORTABLE RADIO SOLUTION DESCRIPTION

OVERVIEW

The APX N30 offers affordable, next generation communications without compromising P25 interoperability or voice and data quality. It has a durable design with “pick-up-and-go” functionality, optimizing ease-of-use and focused communications in almost all environments.

DURABLE AND EASY TO USE

The APX N30 enhances operations with a front display with an upgraded user interface for better readability and loud and clear audio for reliable, everyday use. Additionally, the N30 offers extended battery life, a shorter antenna, and Bluetooth compatibility with audio accessories, promoting efficient communications between first responders.

ViQi Voice Command

To prevent first responders from losing focus while events unfold, ViQi Voice Control allows users to operate their device with customized voice commands. First responders can switch between preset channels and zones, adjust volume, and change audio profiles by pressing the preprogrammed ViQi button and speaking into the microphone.

ESSENTIAL AND SECURE P25 COMMUNICATIONS

The APX N30 is certified compliant with P25 standards and supports digital and analog trunking, FDMA and TDMA, and Integrated Voice and Data. All P25 communications over the N30 are safe and secure—it offers software encryption, single- and multi key encryption, and P25 Authentication, protecting communications during daily operations.

RELIABLE CONNECTIVITY

Using the APX N30 lets first responders stay connected across disparate networks. It can be equipped with Wi-Fi®, Bluetooth®, GPS, and Geofence features, bringing future-ready applications, services, and best-in-class connectivity to everyday use. APX N30 radios support 7/800 MHz frequency bands across radio systems, with minimal intervention by the radio user.

SmartConnect over Wi-Fi

SmartConnect is a subscription service that allows first responders to access critical intelligence no matter where the mission takes them. When P25 networks are unavailable, the APX N30 will maintain functionality and voice quality by automatically switching to an available broadband network, enabling connectivity outside of {{CustomerName Possessive}} radio system coverage. Voice information and signals between radios and control are encrypted, ensuring that all transmissions are secure.

The APX N30 can use SmartConnect when directly connected to Wi-Fi hotspots, through an in-vehicle LTE modem, or over a satellite connection. Additionally, the radio will indicate to users when SmartConnect is active by displaying a blue bar on-screen.

MANAGING AND PROVISIONING DEVICES

APX N50 can be programmed in two ways: one-at-a-time through Customer Programming Service (“CPS”) or through a combination of CPS and batch programming over Wi-Fi available with the radio management (“RM”) software.



CPS is a proprietary, Windows-based application, used to configure APX subscriber radios in offline situations that include provisioning, networking, and monitoring tools that provide greater awareness and faster radio management. The CPS application offers drag-and-drop, clone-wizard, and basic import/export functions that allow the addition of new software and feature enhancements. APX N radios can be programmed one-at-a-time on a local PC, via secure USB port connection, with TLS-PSK based encryption. Once loaded, subscriber radios are read and edited, and codeplugs and templates can be saved and duplicated to program other fleet radios.

Batch Programming is available through the RM software for simultaneous programming and upgrading throughout the radio fleet. With Batch Programming, up to 16 radios can be programmed at once over a Wi-Fi connection. This reduces programming time and ensures that the radio fleet is always up-to-date and ready-to-use in the field.

Device Management Services

Device Management Services ("DMS") packages provide programming, management, and maintenance services to maximize the effectiveness of this APX N50 solution, while reducing maintenance risk, workload, and total cost of ownership. DMS tackles a range of customer needs, whether the solution is self-maintained or managed by Motorola Solutions.



APX N-SERIES DEVICE MANAGEMENT SERVICES - ESSENTIAL STATEMENT OF WORK

OVERVIEW

Device Management Services (“DMS”) efficiently maintains the Customer’s device fleet while helping to keep devices up-to-date and fully operational in the field.

DMS Essential services provide basic hardware and software support.

This Statement of Work (“SOW”), including all of its subsections and attachments is an integral part of the applicable agreement (“Agreement”) between Motorola Solutions, Inc. (“Motorola Solutions”) and Customer (“Customer”).

In the event of a conflict between the terms and conditions of the Agreement and the terms and conditions of this SOW, this SOW will control as to the inconsistency only. The SOW applies to the device specifically named in the Agreement.

HARDWARE REPAIR

Hardware Repair provides repair coverage for internal and external device components that do not work in accordance with published specifications. Repair services are performed at a Motorola Solutions-operated or supervised facility. The device will be repaired to bring it to compliance with its specifications, as published by Motorola Solutions at the time of delivery of the original device.

For malfunctioning devices that must be replaced, Motorola Solutions will attempt to read the codeplugs from those devices. If successful, Motorola Solutions will load the codeplug to any replacement devices. If not, Motorola Solutions will load a factory codeplug, and the Customer will need to load the previous codeplug.

Motorola Solutions will load factory available firmware to any replacement devices, which may not match the Customer’s firmware version.

MOTOROLA SOLUTIONS RESPONSIBILITIES

- Repair or replace malfunctioning device, as determined by Motorola Solutions.
- Complete repair or replacement with a turnaround time of five business days in-house, provided the device is delivered to the repair center by 9:00 a.m. (local repair center time). Turnaround time represents the time a product spends in the repair process, and does not include time in transit to and from the Customer’s site. Business days do not include US holidays or weekends.
- If applicable, apply periodically-released device updates, in accordance with an Engineering Change Notice.
- Provide two-way air shipping when a supported Motorola Solutions electronic system, such as MyView Portal, is used to initiate a repair. A shipping label will be generated via the electronic system.

CUSTOMER RESPONSIBILITIES

- For non-contiguous renewals, Customer must provide a complete list, preferably in electronic format, of all hardware serial numbers to be covered under the Agreement to Motorola Solutions.
- Initiate device repairs, as needed.
 - When initiating a repair via a supported Motorola Solutions electronic system, label each package correctly with the shipping label and Return Material Authorization (“RMA”) number generated by the electronic system.
 - When initiating a repair via paper Return Material Form (“RMF”), the RMF must be completed for each device, included in the package with the device, and shipped to the Motorola Solutions depot specified on the RMF.
- Remove any data or other information from the device that the Customer wishes to destroy or retain prior to sending the device for repair.



- If a malfunctioning device must be replaced and the Customer has loaded information for that device to Motorola Solutions' cloud environment, the Customer will need to remove the information for the malfunctioning device and add information for the replacement device to the applicable cloud environment.

LIMITATIONS AND EXCLUSIONS

The Customer will incur additional charges at the prevailing rates for any activities that are not included or are specifically excluded from this service scope, as described below. Motorola Solutions will notify the Customer and provide a quotation of any incremental charges related to such exclusions prior to completing the repair and said repair will be subject to Customer's acceptance of the quotation.

- Replacement of consumable parts or accessories, as defined by product, including but not limited to batteries, cables, and carrying cases.
- Repair of problems caused by:
 - Natural or manmade disasters, including but not limited to internal or external damage resulting from fire, theft, and floods.
 - Third-party software, accessories, or peripherals not approved in writing by Motorola Solutions for use with the device.
 - Using the device outside of the product's operational and environmental specifications, including improper handling, carelessness, or reckless use.
 - Unauthorized alterations or attempted repair, or repair by a third party.
- Non-remedial work, including but not limited to administration and operator procedures, reprogramming, and operator or user training.
- Problem determination and/or work performed to repair or resolve issues with non-covered products. For example, any hardware or software products not specifically listed on the service order form are excluded from service.
- File backup or restoration.
- Completion and test of incomplete application programming or system integration if not performed by Motorola Solutions and specifically listed as covered.
- Accidental damage, chemical or liquid damage, or other damage caused outside of normal device operating specifications, except if optional Accidental Damage Coverage was purchased.
- Cosmetic imperfections that do not affect the functionality of the device.
- Software support for unauthorized modifications or other misuse of the device software is not covered.

Motorola Solutions is not obligated to provide support for any device that has been subject to the following:

- Repaired, tampered with, altered or modified (including the unauthorized installation of any software) — except by Motorola Solutions authorized service personnel.
- Subjected to unusual physical or electrical stress, abuse, or forces or exposure beyond normal use within the specified operational and environmental parameters set forth in the applicable product specification.
- If the Customer fails to comply with the obligations contained in the Agreement, the applicable software license agreement, and Motorola Solutions terms and conditions of service.

DEVICETECHNICALSUPPORT

Motorola Solutions' Device Technical Support service provides telephone consultation for device and accessory issues. Support is delivered through the Motorola Solutions Centralized Managed Support Operations ("CMSO") organization by a staff of technical support specialists.

For Device Technical Support, Motorola Solutions will respond to calls within two (2) hours during the support days. Support hours are 7 a.m. to 7 p.m. CST Monday through Friday, excluding US holidays. In addition, Customers may contact the Call Management Center (800-MSI-HELP) at any time (24 hours a day, seven days a week) and a Motorola Solutions representative will log a technical request in Motorola Solutions Case Management System on the Customer's behalf.



MOTOROLA SOLUTIONS RESPONSIBILITIES

- Provide technical support for devices, assessing and troubleshooting reported issues.
- Receive and log Customer support requests, and assign a technical representative to respond to a Customer incident per the defined timeframes.

CUSTOMER RESPONSIBILITIES

- Use the provided methods to contact Motorola Solutions technical support.
- Provide sufficient information to allow Motorola Solutions technical support agents to diagnose and resolve Customer issues.
- Provide contact information for field service technicians in the event that Motorola Solutions has to follow up.

LIMITATIONS AND EXCLUSIONS

- Device support does not include Land Mobile Radio ("LMR") network, Wi-Fi, and LTE network troubleshooting.

Software Maintenance

Motorola Solutions is continually developing new features and functionality for our portfolio of public-safety-grade radios. By purchasing software maintenance, the Customer can take advantage of these firmware releases and future-proof their communications investment.

MOTOROLA SOLUTIONS RESPONSIBILITIES

- Test all firmware releases to minimize software defects.
- Announce new firmware releases and post release notes in a timely manner via MyView Portal.
- Provide firmware updates. Motorola Solutions makes no guarantees as to the frequency or timing of firmware updates.
- Provide upgrade capability through supported Programming Tools.
- Provide programming and service tools and technical support through the firmware support window.
- Provide documentation via MyView Portal with each release detailing new features, bug fixes, and any known issues.

CUSTOMER RESPONSIBILITIES

- Periodically check MyView Portal for firmware update announcements.
- Keep the radio fleet updated with firmware versions within the support window.

MyView Portal Access

MyView Portal is the single location to track the status of subscriptions and service contracts, including start and end dates. This portal includes order, RMA, and technical support ticket status, as well as a consolidated download site for software and documentation.

Outside of pre-announced maintenance periods, MyView Portal will be available on a best effort 24/7 basis. Motorola Solutions cannot guarantee the availability of Internet networks outside of our control.

MOTOROLA SOLUTIONS RESPONSIBILITIES

- Provide a web accessible, secure portal to view the Customer's data.
- Provide the Customer with login credentials for the site.
- Provide end-user training for the site.
- Provide technical support to answer end user questions between the hours of 8 a.m. to 5 p.m. CST Monday through Friday, excluding US holidays.



- Keep the site updated with the latest Customer information.

CUSTOMER RESPONSIBILITIES

- Provide Motorola Solutions with contact information for administrative users.
- Administer user access.
- Provide Internet access for users to access the site.
- Attend available MyView Portal training.
- Protect login information against unauthorized use.
- Provide Motorola Solutions with updated equipment information, as needed.



Purchase Order Checklist NA OM

Marked as PO/ Contract/ Notice to Proceed on Company Letterhead (PO will not be processed without this)
PO Number/ Contract Number
PO Date
Vendor = Motorola Solutions, Inc.
Payment (Billing) Terms/ State Contract Number
Bill-To Name on PO must be equal to the <i>Legal</i> Bill-To Name
Bill-To Address
Ship-To Address (If we are shipping to a MR location, it must be documented on PO)
Ultimate Address (If the Ship-To address is the MR location then the Ultimate Destination address must be documented on PO)
PO Amount must be equal to or greater than Order Total
Non-Editable Format (Word/ Excel templates cannot be accepted)
Tax Exemption Status
Signatures (As required)

NOTE: When an email order is submitted a confirmation is sent from Motorola AutoNotify referencing a **case number**.

Once checklist is complete, order still must go through **Order Validation/Credit Approval**



February 21, 2026

City of Pryor
Attn: Zac Doyle – Mayor
12 N. Rowe; Suite B
Pryor, OK 74361

Re: PRY-24-02-01 Pryor Elliott Street Drainage Improvements
Invoice: PRY-24-02-01

Dear Mr. Doyle:

Enclosed, please find invoice PRY-24-02-01. Please place this invoice on the agenda for approval at your next meeting.

Once approved, please forward a check to Infrastructure Solutions Group, LLC's McAlester office at 100 East Carl Albert Parkway; McAlester, OK 74501.

Please note the change in the address.

If you have any questions concerning these documents, please contact me at (918) 420-5500.

Sincerely,
Infrastructure Solutions Group, LLC

Dale Burke, P.E.
President

Project # PRY-24-02



INVOICE SUBMITTED TO:

February 21, 2026

City of Pryor Creek
 12 North Rowe, Suite B
 Pryor Creek, OK 74361

Invoice #: PRY-24-02-01

In Reference To: Pryor Elliott Street Drainage Improvements

Engineering Design Wilkerson to 10th Street:	\$25,000.00	(100% Complete)	\$25,000.00
Engineering Bidding and Construction Management:	\$5,000.00	(95% Complete)	\$4,750.00
Design Survey:	\$10,000.00	(100% Complete)	\$10,000.00
Resident Project Representative (Hourly):	\$85.00	(125 Hours)	\$10,625.00
Total Engineering Services Billed to Date:			\$50,375.00
Less Previously Invoiced:			\$0.00
<u>TOTAL DUE THIS INVOICE</u>			<u>\$50,375.00</u>

Please send payments to:

Infrastructure Solutions Group, LLC
100 East Carl Albert Parkway
McAlester, OK 74501

CITY OF PRYOR CREEK, OKLAHOMA

FINANCIAL STATEMENTS

JUNE 30, 2024

**HOOD & ASSOCIATES CPA'S, PC
CERTIFIED PUBLIC ACCOUNTANTS
TULSA, OKLAHOMA**

**CITY OF PRYOR CREEK
TABLE OF CONTENTS
FINANCIAL STATEMENTS
JUNE 30, 2024**

	Page
Independent Auditor's Report	1
Management's Discussion and Analysis (Unaudited)	
Part I	4
Part II	12
Statement of Net Position (Statement 1)	22
Statement of Activities (Statement 2)	23
Balance Sheet, Governmental Funds (Statement 3)	25
Statement of Revenues, Expenditures, and Changes in Fund Balances, Governmental Funds (Statement 4)	27
Statement of Net Position, Proprietary Funds (Statement 5)	30
Statement of Revenues, Expenses and Changes in Net Position, Proprietary Funds (Statement 6)	31
Statement of Cash Flows, Proprietary Funds (Statement 7)	32
Notes to Basic Financial Statements - Index	34
Notes to Basic Financial Statements	35
Required Supplementary Information	69
Required Supplementary Information - Pension Plan Funding Progress	70
Required Supplementary Information	74
Budgetary Comparison Schedule, General Fund	75
Other Supplementary Information	77
Combining Balance Sheet - Non-Major Governmental Funds	78
Combining Statement of Revenues, Expenditures, and Changes in Fund Balances - Non-Major Governmental Funds	81
Report on Internal Control over Financial Reporting and on Compliance and Other Matters Based on an Audit of Financial Statements Performed in Accordance with Government Auditing Standards	84
Schedule of Findings and Responses – Prior Year	86
Schedule of Findings and Responses – Current Year	87



Independent Auditor's Report

Board of Trustees
City of Pryor Creek, Oklahoma

Report on the Audit of the Financial Statements

Opinions

We have audited the financial statements of the governmental activities, the business-type activities, the aggregate discretely presented component units, each major fund, and the aggregate remaining fund information of the City of Pryor Creek, Oklahoma as of and for the year ended June 30, 2024, and the related notes to the financial statements, which collectively comprise the City's basic financial statements as listed in the table of contents.

In our opinion, the accompanying financial statements referred to above present fairly, in all material respects, the respective financial position of the governmental activities, the business-type activities, the aggregate discretely presented component units, each major fund, and the aggregate remaining fund information of the City, as of June 30, 2024, and the respective changes in financial position, and, where applicable, cash flows thereof for the year then ended in accordance with accounting principles generally accepted in the United States of America.

Basis for Opinions

We conducted our audit in accordance with auditing standards generally accepted in the United States of America (GAAS) and the standards applicable to financial audits contained in Government Auditing Standards issued by the Comptroller General of the United States (Government Auditing Standards). Our responsibilities under those standards are further described in the Auditor's Responsibilities for the Audit of the Financial Statements section of our report. We are required to be independent of the City and to meet our other ethical responsibilities, in accordance with the relevant ethical requirements relating to our audit. We believe that the audit evidence we have obtained is sufficient and appropriate to provide a basis for our audit opinions.

HOOD & ASSOCIATES CPAs, P.C.

WWW.AUDIT.HOODCPAS.COM

Responsibilities of Management for the Financial Statements

Management is responsible for the preparation and fair presentation of the financial statements in accordance with accounting principles generally accepted in the United States of America, and for the design, implementation, and maintenance of internal control relevant to the preparation and fair presentation of financial statements that are free from material misstatement, whether due to fraud or error.

In preparing the financial statements, management is required to evaluate whether there are conditions or events, considered in the aggregate, that raise substantial doubt about the City's ability to continue as a going concern for twelve months beyond the financial statement date, including any currently known information that may raise substantial doubt shortly thereafter.

Auditor's Responsibilities for the Audit of the Financial Statements

Our objectives are to obtain reasonable assurance about whether the financial statements as a whole are free from material misstatement, whether due to fraud or error, and to issue an auditor's report that includes our opinions. Reasonable assurance is a high level of assurance but is not absolute assurance and therefore is not a guarantee that an audit conducted in accordance with GAAS and Government Auditing Standards will always detect a material misstatement when it exists. The risk of not detecting a material misstatement resulting from fraud is higher than for one resulting from error, as fraud may involve collusion, forgery, intentional omissions, misrepresentations, or the override of internal control. Misstatements are considered material if there is a substantial likelihood that, individually or in the aggregate, they would influence the judgment made by a reasonable user based on the financial statements.

In performing an audit in accordance with GAAS and *Government Auditing Standards*, we

- exercise professional judgment and maintain professional skepticism throughout the audit.
- identify and assess the risks of material misstatement of the financial statements, whether due to fraud or error, and design and perform audit procedures responsive to those risks. Such procedures include examining, on a test basis, evidence regarding the amounts and disclosures in the financial statements.
- obtain an understanding of internal control relevant to the audit in order to design audit procedures that are appropriate in the circumstances, but not for the purpose of expressing an opinion on the effectiveness of the City's internal control. Accordingly, no such opinion is expressed.
- evaluate the appropriateness of accounting policies used and the reasonableness of significant accounting estimates made by management, as well as evaluate the overall presentation of the financial statements.
- conclude whether, in our judgment, there are conditions or events, considered in the aggregate, that raise substantial doubt about the City's ability to continue as a going concern for a reasonable period of time.

We are required to communicate with those charged with governance regarding, among other matters, the planned scope and timing of the audit, significant audit findings, and certain internal control—related matters that we identified during the audit.

Required Supplementary Information

Accounting principles generally accepted in the United States of America require that the management's discussion and analysis and budgetary comparison be presented to supplement the basic financial statements. Such information is the responsibility of management and, although not a part of the basic financial statements, is required by the Governmental Accounting Standards Board who considers it to be an essential part of financial reporting for placing the basic financial statements in an appropriate operational, economic, or historical context. We have applied certain limited procedures to the required supplementary information in accordance with GAAS, which consisted of inquiries of management about the methods of preparing the information and comparing the information for consistency with management's responses to our inquiries, the basic financial statements, and other knowledge we obtained during our audit of the basic financial statements. We do not express an opinion or provide any assurance on the information because the limited procedures do not provide us with sufficient evidence to express an opinion or provide any assurance.

Other Reporting Required by Government Auditing Standards

In accordance with Government Auditing Standards, we have also issued our report dated February 24, 2026 on our consideration of the City's internal control over financial reporting and on our tests of its compliance with certain provisions of laws, regulations, contracts, and grant agreements and other matters. The purpose of that report is solely to describe the scope of our testing of internal control over financial reporting and compliance and the results of that testing, and not to provide an opinion on the effectiveness of the City's internal control over financial reporting or on compliance. That report is an integral part of an audit performed in accordance with Government Auditing Standards in considering City's internal control over financial reporting and compliance.



Hood & Associates CPAs, PC
February 24, 2026

**CITY OF PRYOR CREEK, OKLAHOMA
MANAGEMENT'S DISCUSSION AND ANALYSIS
(UNAUDITED)
JUNE 30, 2024**

The discussion and analysis of the City of Pryor Creek's financial performance provides an overview and analysis of the City's financial activities for the fiscal year ended June 30, 2024. It should be read in conjunction with the accompanying basic financial statements.

This discussion is divided into two parts. The first pertains to the entire City of Pryor Creek overall with very little detail to the Municipal Utility Department, a department of the City of Pryor Creek. The second part pertains to the Municipal Utility Department, which was created by the Charter for the City of Pryor Creek and operates under the Utility Board of five members as explained in the notes to the financial statements.

PART I

WHO WE ARE

As of June 30, 2024, the mayor, council members, clerk, and treasurer, all of whom are elected, consisted of the following:

Mayor	Zac Doyle
Council Members	John Choya Shropshire Lori Bradshaw Bruce Smith Kenneth Brashears Terry Lamar Tyler Brown Charles Tramel Christopher Gonthier
Clerk	Courtney Davis
Treasurer	Lori Ballew

OVERVIEW OF THE BASIC FINANCIAL STATEMENTS

Management's Discussion and Analysis is intended to serve as an introduction to the City's basic financial statements. In accordance with Governmental Accounting Standards Board Statement No. 34, "Basic Financial Statements - and Managements' Discussion and Analysis - for State and Local Governments," ("GASB 34"), the City's basic financial statements include three components: government-wide financial statements; fund financial statements; and notes to the basic financial statements. The major features of these financial statements are summarized as follows:

	<u>Government-wide Statements</u>	<u>Governmental Funds</u>	<u>Proprietary Funds</u>
Scope	Entire City government and the City's component units	The activities of the City that are not proprietary, such as police, fire, library, streets, etc.	Activities the City operates similar to private businesses such as utilities and the golf course
Required financial statements	-Statement of net position -Statement of activities	-Balance sheet -Statement of revenues, expenditures, and changes in fund balances	-Statement of net position -Statement of revenues, expenses, and changes in net position -Statement of cash funds
Accounting basis and measurement focus	Accrual accounting and economic resources focus	Modified accrual accounting and current financial resources focus	Accrual accounting and economic resources focus
Type of asset/liability information	All assets and liabilities, both financial and capital, and short-term and long-term	Only assets expected to be used up and liabilities that come due during the year or soon thereafter; no capital assets included	All assets and liabilities, both financial and capital, and short-term and long-term
Type of inflow/outflow information	All revenues and expenses during year, regardless of when cash is received or paid	Revenues for which cash is received during or soon after the end of the year; expenditures when goods or services have been received and payment is due during the year or soon thereafter	All revenues and expenses during year, regardless of when cash is received or paid

Government-wide financial statements. The *government-wide financial statements* are designed to provide readers with a broad overview of the City's finances, in a manner similar to statements of a private-sector business.

The *statement of net position* presents information on all the City's assets and liabilities, with the difference between the two reported as net position. Over time, increases or decreases in net position may serve as a useful indicator of whether the financial position of the City is improving or deteriorating.

The *statement of activities* presents information showing how the City's net position changed during the most recent fiscal year. All changes in net position are reported as soon as the underlying event giving rise to the change occurs, *regardless of the timing of related cash flows*.

Thus, revenues and expenses are reported in this statement for some items that will result in cash flows in future fiscal periods.

The government-wide financial statements distinguish functions of the City that are principally supported by taxes and intergovernmental revenues (governmental activities) from other functions that are intended to recover all or a significant portion of their costs through user fees and charges (business-type activities). The governmental activities of the City include public safety activities, streets, cultural, library, parks and recreation activities and general government activities. The business-type activities of the City include utilities and a golf course.

A component unit is included in the basic financial statements and consists of a legally separate entity for which the City is financially accountable and that has the same governing board as the City. This blended component unit is the Pryor Public Works Authority. The County Wide Fire Department Fund is also blended into the financial statements.

The government-wide financial statements can be found on Statements 1 and 2 of this report.

Fund financial statements. A *fund* is a grouping of related accounts that is used to maintain control over resources that have been segregated for specific activities or objectives. The City, like other state and local governments, uses fund accounting to ensure and demonstrate compliance with finance-related legal requirements. All the funds of the City can be divided into two categories: governmental funds and proprietary funds.

Governmental funds. *Governmental funds* are used to account for essentially the same functions reported as governmental activities in the government-wide financial statements. However, unlike the government-wide financial statements, governmental fund financial statements focus on near-term inflows and outflows of spendable resources, as well as on balances of spendable resources available at the end of the fiscal year. Such information may be useful in evaluating the City's near-term financing requirements.

Because the focus of governmental funds is narrower than that of the government-wide financial statements, it is useful to compare the information presented for governmental funds with similar information presented for governmental activities in the government-wide financial statements. By doing so, readers may better understand the long-term impact of the City's near-term financing decisions. Both the governmental funds balance sheet and the governmental funds statements of revenues, expenditures and changes in fund balance provide a reconciliation to the government-wide financial statements in order to facilitate this comparison between governmental funds and governmental activities.

The City maintains 20 individual governmental funds for financial reporting purposes. Information is presented separately in the governmental funds balance sheet and in the governmental funds statement of revenues, expenditures, and changes in fund balances for the General, Street and Drainage and the Recreation Center Construction Fund, which are considered to be major funds. Data for the other 17 governmental funds are combined into a single, aggregated presentation. Individual fund data for each of these non-major governmental funds is provided in the non-major funds supplementary section of this report.

The City adopts an annual appropriated budget for its General Fund and some of its special revenue funds and capital project funds. A budgetary comparison statement has been provided for the General Fund and the Street and Drainage Fund in the basic financial statements.

The governmental funds financial statements can be found in Statements 3 and 4 of this report.

Proprietary funds. Proprietary funds provide the same type of information as the government-wide financial statements but in more detail. The proprietary fund financial statements provide separate information for the utility and golf course operations. Combining schedules for the proprietary funds are presented in the supplementary information.

The proprietary funds financial statements can be found at Statements 5, 6, and 7 of this report.

Notes to the basic financial statements. The notes to the basic financial statements provide additional information that is essential to a full understanding of the data provided in the government-wide and fund financial statements. The notes to the basic financial statements can be found beginning on page 37 of this report.

GOVERNMENT-WIDE FINANCIAL ANALYSIS

Statements 1 and 2 reflect an increase in net position of \$404,080, consisting of:

	<u>6/30/2024</u>	<u>6/30/2023</u>	Increase <u>(Decrease)</u>
Invested in capital assets, net of related debt	\$ 80,060,695	\$ 77,234,263	\$ 2,826,432
Restricted for capital projects and emergencies	12,526,506	15,579,884	(3,053,378)
Restricted for debt service	886,266	801,736	84,530
Restricted for other	3,494,649	2,281,214	1,213,435
Unrestricted	<u>4,427,555</u>	<u>5,094,494</u>	<u>(666,939)</u>
Total	<u>\$101,395,671</u>	<u>\$100,991,591</u>	<u>\$ 404,080</u>

The overall increase of \$404,080 is considered relatively healthy.

The decrease in “Restricted for Capital Projects and Emergencies” is due mainly to an increase in capital activity related to these funds.

The increase in “Restricted for Debt Service” is mainly due to a decrease in capital activity related to these funds.

The “Restricted for Other” for all except the Municipal Utility Department consists of funds for special functions such as Rec Center, Golf Course, Fire, Library, etc. The increase is mainly due to a decrease in capital activity related to these funds.

The decrease in “unrestricted” of \$607,922 represents an 11.9% decrease from the prior year balance and is considered good, as these funds are unrestricted to usage as the name indicates. Of primary importance is the General Fund, which will be discussed in Statements 3 and 4 next.

FINANCIAL ANALYSIS OF THE CITY'S MAJOR FUNDS

Statements 3 and 4 generally represent a “cash flow” of the funds, as loan proceeds and payments are recorded as income and expenditures respectively and capital outlay as expenditures. Also, no depreciation is reflected as an expense. The main difference to a true “cash flow” is that the operating receivables and payables are reflected on such statements.

The General Fund is the main governmental fund, as it pays for almost all the operating expenses of the City. The fund balance decreased by \$828,401 from \$3,106,543 to \$2,278,142. This, combined with a \$926,275 decrease at 6/30/2023, means that the General Fund balance has decreased \$1,754,676.

A revenue comparison is shown below.

	General Fund		
	Revenues 6/30/24	Revenues 6/30/23	Increase (Decrease)
Sales tax	\$ 5,079,430	\$ 4,978,703	\$ 100,727
Use tax	1,209,052	1,082,770	126,282
Other taxes	196,567	205,324	(8,757)
Police fines	221,937	147,592	74,345
Licenses and permits	103,793	157,778	(53,985)
Franchise taxes	28,521	56,063	(27,542)
Fees and service	80,671	73,058	7,613
Interest	58,763	45,143	13,620
Miscellaneous	7,256	20,534	(13,278)
Grants and contributions	109,997	33,633	76,364
Transfer from MUB	775,200	775,200	--
Other transfers	415,088	412,996	2,092
Reimbursement	335,941	421,876	(85,935)
Totals	<u>\$ 8,622,216</u>	<u>\$ 8,410,670</u>	<u>\$ 211,546</u>

Total overall revenue was stagnant. There were fluctuations of individual categories. Sales tax increased slightly. Use tax increased slightly. Police fines increased. Grants and contributions increased significantly. Fees and services increased, while other taxes decreased slightly. MUB transferred amounts per charter required calculations.

Municipal Utility Department See Part II of this discussion.

GENERAL FUND BUDGETARY

The following Table 3 presents a summary analysis of the General Fund budget and actuals for the current fiscal year.

**TABLE 3
CITY OF PRYOR CREEK
SUMMARY ANALYSIS OF GENERAL FUND BUDGET
FISCAL YEAR ENDING JUNE 30, 2024**

<u>Category</u>	<u>Budgeted Amounts</u>		<u>Actual (Budget Basis)</u>	<u>Variance Positive (Negative)</u>
	<u>Adopted</u>	<u>Final</u>		
Revenue				
Sales tax	\$ 4,616,325	\$ 4,616,325	\$ 5,129,250	\$ 512,925
All other taxes	1,160,203	1,160,203	1,289,114	128,911
All other revenues	<u>1,307,382</u>	<u>1,307,382</u>	<u>1,381,112</u>	<u>73,730</u>
Total revenues	<u>7,083,910</u>	<u>7,083,910</u>	<u>7,799,476</u>	<u>715,566</u>
Expenditures				
General government (1)	1,857,507	1,857,507	1,385,964	(471,543)
Public safety (2)	6,373,873	6,373,873	6,704,038	330,165
Cultural and recreation services (3)	<u>988,928</u>	<u>988,928</u>	<u>1,272,382</u>	<u>283,454</u>
Total expenditures	<u>9,220,308</u>	<u>9,220,308</u>	<u>9,362,384</u>	<u>142,076</u>
Total excess (deficiency) of revenues over expenditures	(2,136,398)	(2,136,398)	(1,562,908)	573,490
Other financing sources (uses)				
Transfers (Net)	775,200	775,200	775,200	--
Beginning fund balance	<u>1,361,198</u>	<u>1,361,198</u>	<u>1,361,198</u>	<u>--</u>
Excess (deficiency) of revenues and other sources over expenditures and other uses	<u>\$ --</u>	<u>\$ --</u>	<u>\$ 573,490</u>	<u>\$ 573,490</u>

- (1) Includes General Government, City Clerk, City Treasurer, City Attorney and Planning and Zoning, and Building Inspector, Maintenance Garage and Flood Plain Board
- (2) Includes Municipal Court, Police, Fire, Dog Pound and Civil Emergency Management
- (3) Includes Parks, Pool, Library and Cemetery

The basis of accounting for budgetary purposes for the General Fund is the modified accrual, i. e., revenues are recognized when received and expenses are recognized when encumbered.

The budget method authorized by Oklahoma Statute adopted by the City for its general fund places a limit on the amount that can be budgeted. The amount to be budgeted for the next fiscal year is the unreserved fund balance at the beginning of the fiscal year plus 90% of its revenues for the year just ended. An exception to this is that 100% of the funds budgeted by the Municipal Utility Department to be transferred to the City's General Fund in accordance with the City Charter is budgeted.

The budgetary fund balance is reconciled to the balance sheet fund balance in the Required Supplementary Information.

Generally, the City attempts to prepare a budget that will result in a small positive increase in the fund balance. Generally, this is accomplished by only budgeting 90% of the prior year revenues and budgeting amounts, primarily in General Government, that will not be expended.

CAPITAL ASSET AND DEBT ADMINISTRATION

Capital Assets

The City's governmental investment in capital assets as of June 30, 2024 amounted to \$55,955,632 (net of accumulated depreciation and exclusive of related debt). This investment, detailed in Note 3.D. to the financial statements, in a broad range of capital assets includes land, structures and improvements, equipment, and construction in progress.

I invite you to review Note 3.D Capital Assets to the Financial Statements, which is included herein and details the capital asset activity. Also, see Part II for further discussion concerning the Municipal Utility Department.

Long-term Debt

Long-term debt has already been discussed in this report.

Additional information on long-term debt is included in Note 3.G to the financial statements.

ECONOMIC FACTORS AND NEW YEAR'S BUDGET

Revenues appear to be flat, but inflation is causing expenditures to increase. The City will need to watch their expenditures carefully.

Currently, all funds are healthy.

CONTACTING THE CITY'S FINANCE DEPARTMENT

This management's discussion and analysis is designed to provide citizens, taxpayers, customers and investors and creditors with a general overview of the City's finances and to demonstrate the City's accountability for the money it receives. If you have questions or need additional financial information, please contact the City of Pryor Creek at (918) 825-0888.

PART II

WHO WE ARE

The Municipal Utility Department, City of Pryor Creek Oklahoma was created by the Pryor Creek City Charter in 1951. The current five-person board is listed below.

Chairman:	Mr. Garry J. Harris
Vice-Chairman:	Ms. Lorri Mitchell
Secretary:	Dr. Ken Rains
Member:	Mr. Mark Roberts
Member:	Dr. Arthur Sixkiller

The Utility Board has the care, custody, and management of the existing electric system, water system, gas distribution system, street lighting system, and sewage disposal system and may enlarge and extend them under the guidelines of the City Charter. The Board has under its control, the complete operation of these utilities and such other as the people of the City of Pryor Creek may acquire. All of these utilities shall be collectively known as the Municipal Utility Department.

The Utility Board shall employ all persons necessary in the operation of the utilities and fix their salaries, condition of servitude, and terms of office, and shall adopt such rules and regulations, as it may deem necessary for the proper conduct of business.

USING THE ANNUAL REPORT

This annual report consists of a series of financial statements. The Statement of Net Position (page 12) and Statement of Revenues, Expenses and Changes in Net Position (page 13) document the income and expenses (on a full accrual basis) of the Utility Board for the current fiscal year, and how they affect the Net Position of the Board. Net Position are ALL assets of the Board less ALL liabilities.

The Statement of Cash Flows (page 14) documents the sources and uses of cash, and shows whether cash increased or decreased during the current fiscal year. Notes to the financial statements (page 16) provide additional detail that further explain information found in the various statements.

FINANCIAL SUMMARY

The following presents the management overview and analysis of the Municipal Utility Board's financial condition and performance for the fiscal years ended June 30, 2023 and June 30, 2024, and proposed projects for fiscal year ending June 30, 2024.

For the years ended, Net Position changed as follows:

	June 30, <u>2024</u>	June 30, <u>2023</u>
Beginning net position	\$42,696,221	\$41,327,607
Increase in net position	<u>1,434,787</u>	<u>1,368,614</u>
Ending net position	<u>\$44,131,008</u>	<u>\$42,696,221</u>

Included in net position are amounts reserved for specific long-term purposes. The following reserve accounts have been funded by excess revenues over several fiscal years.

	June 30, <u>2024</u>	June 30, <u>2023</u>
Reserve for extension, capital improvements	\$ 1,413,108	\$ 1,533,463
Reserve for emergency and natural disasters	<u>1,587,600</u>	<u>1,587,600</u>
	\$ 3,000,708	\$ 3,121,063
Reserve for capital improvements from sales Tax. This reserve is funded by \$0.005 sales tax and interest revenue. This account is used to fund the Wastewater Treatment Plant Depreciation Account; excess funds will be used for utility tensions.	<u>6,037,335</u>	<u>7,481,824</u>
Total	<u>\$ 9,038,043</u>	<u>\$10,602,887</u>

The primary source of revenues generated by the board are sales of utilities to its customers. Revenues are as follows:

	June 30, <u>2024</u>	June 30, <u>2023</u>
Operating revenues	\$16,726,758	\$18,037,963
Sales tax revenue	1,354,514	1,327,654
Interest income	387,581	314,047
Gain on asset disposal	--	83,814
Grant income	<u>18,978</u>	<u>20,971</u>
Total revenues	<u>\$18,487,831</u>	<u>\$19,784,449</u>

Utilities are purchased and then resold to Municipal Utility Board Customers. The annual cost of purchased utilities is \$10,936,807 and \$9,247,956 for the fiscal years ending June 30, 2023 and June 30, 2024 respectively.

Expenses are as follows:

	June 30, <u>2024</u>	June 30, <u>2023</u>
Operating expenses	\$16,256,146	\$17,640,635
Loss on asset disposal	2,469	--
Interest expense	<u>19,229</u>	<u>--</u>
Total expenses	<u>\$16,277,844</u>	<u>\$17,640,635</u>

Percentages by expense category are as follows:

	June 30, <u>2024</u>	June 30, <u>2023</u>
Purchased utilities	57%	63%
Payroll and related expenses	28%	24%
Operation, maintenance and other	<u>15%</u>	<u>13%</u>
	<u>100%</u>	<u>100%</u>

The resulting net income before contributions and transfer is \$2,143,814 and \$2,209,987 for the fiscal years ending June 30, 2023 and 2024 respectively. The Board transfers to the City of Pryor Creek General fund an agreed upon amount of \$775,200. The amounts for 2023 and 2024 were both this amount, as is the projected amount to be transferred for the fiscal year ending June 30, 2025.

DEPARTMENT ACCOMPLISHMENTS

ADMINISTRATIVE DEPARTMENT

Fiscal Year Ending June 30, 2024

1. Replaced eight (8) business chairs in the board room and four (4) office desk chairs for the business office
2. Acquired water easement at 3066 West 530 (Sugar Bear Courts) by paying Joels Plumbing and Drain a fee of \$2,500 to cap water line
3. Approved \$2,000,000 capital improvement project to install AMI gas and water in Zone 3 (about ½ of the system)
4. Approved to participate in GRDA 2023 Advanced Metering Infrastructure Financial Program for electric meters

5. Acquired 11 acres (more or less) from State of Oklahoma OKARNG for work performed, which ended the monthly \$250 security light bill in December 2023 and the \$3,000 annual pole yard lease agreement
6. Entered into an agreement with Tyler Technologies for utility meter data sync with scheduler software, additional utility meter reader interface software, and services for the mass meter swap for Phase I of the gas and water advanced metering infrastructure system and all the electric advanced metering infrastructure system
7. Purchased Apollo Digital signage from Inlighten and four (4) SmartTV Monitors
8. Purchased a Canon Image PROGRAF TX 4100 Z36 wide format 44" with accessories for GIS mapping
9. Redesigned and upgraded mubpryor.org website
10. Replaced nine (9) computers at City Hall, Warehouse, and the Wastewater Treatment Facility.
11. Warehouse upgrade included an addition of two stall bathroom with shower, three insulated storage bays, security fencing with LED lighting, and a walk-through entrance.

Proposed Projects for Fiscal Year Ending June 30, 2025

1. Contract electronic scanning of Municipal Utility Board documents beginning 1951
2. Explore/cost analysis of Laserfiche Cloud SaaS (Software as a service) solution
3. Explore/cost analysis to add an e-statement option compatible to Tyler Technologies Incode software
4. Implementation of an AMI (automated meter infrastructure) solution
5. Explore/cost analysis to replace and upgrade warehouse unit core switch
6. Explore/cost analysis to adding a file server
7. Replacement of remaining eight (8) computers at City Hall, Warehouse, and the Wastewater Treatment Facility
8. Explore/cost analysis to update/move inventory system to independent server located at the warehouse
9. Upgrade Whitaker pole yard

GAS DEPARTMENT

Fiscal Year Ending June 30, 2024

1. New construction and replacement projects in the Gas Department funded out of operating funds in the amount of \$98,052
2. Installed meters on new two-inch poly pipe at 500 N. W Fifth Street
3. Built fusion properties on the four-inch gas line at 4501 South Mill Street
4. Extended 1,300 feet of four-inch gas main to 1700 North Highway 69
5. Extended 275 feet of four-inch gas main to 1365 North Mill Street
6. Extended 800 feet of four-inch gas main to Cherokee Nation HeadStart
7. Extended new four-inch gas main and two-inch gas main to serve “The Meadows at Stonegate Phase II”
8. Built new two-inch gas main to 5377 South Mill Street

Proposed Projects for Fiscal Year Ending June 30, 2025

1. Wrap four-inch gas main around Cherokee Nation HeadStart
2. Extend new two-inch gas main to 2309 NE First Street
3. Build a new four-inch gas main and two-inch gas main to serve “Roosevelt Crossing Addition”
4. Replace a six-inch high-pressure steel (sixty pound) gas line with six-inch high-pressure poly (sixty pound) gas line on Adair Street from Southeast 5th Street to Southeast 9th Street
5. Replace two-inch low pressure steel gas line with two-inch low pressure poly gas line on Adair Street from Southeast 5th Street to Southeast 9th Street
6. Replace two-inch low-pressure steel as line with two-inch low pressure poly gas line on the eastside of Surrey Drive
7. Change steel riser to anodeless risers on North Fairland and Eastmanor additions
8. Build new six-inch gas main from Mayes County Fairground to One Tobacco Road

9. Extend a four-inch gas main from corner of North 433 Road and Graffiti Road to 1521 Clayton Road
10. Implementation Phase I (Zone 3 billing) AMI (Automated Meter Infrastructure) solution with UTS (Utility Technology Services, Inc)
11. Extend a two-inch poly main gas line in Ivy Ridge
12. Extend four-inch gas main to serve True Addition
13. Replace four-inch steel gas line with four-inch poly gas line on North Elliott from 700 North Elliott to 1212 Clayton Road
14. Lower approximately 900 feet of four-inch poly gas line along SE Ninth Street for Pryor Schools Football Stadium

WATER DEPARTMENT

Fiscal Year Ending June 30, 2024

1. New construction and replacement projects in the Water Department funded out of operating funds in the amount of \$180,262
2. Replaced six-inch water main with a twelve-inch water main near 5425 South Mill Street, then extended the twelve-inch line to 4427 West 530 and 5377 South Mill Street with an eight-inch water valve and twelve-inch water valve tied into the eight-inch feed to Oakwood Road
3. Extended two-inch water main to the new warehouse addition at 7 West Gramh Avenue
4. Extended two-inch water main and a six-inch water main to Ivy Ridge 2nd Addition
5. Extended an eight-inch water main to serve 1700 North Highway 69
6. Extended a six-inch water main and installed a six-inch commercial water meter at 1 Tobacco Road
7. Installed a back flow preventer with a two-inch bypass and a four-inch commercial water meter at Pryor Creek Golf Course

Proposed Projects for Fiscal Year Ending June 30, 2025

1. Replace six-inch water line on South Pine
2. Upgrade the cone valve in the “Y” at South Elliott Street and West 510 road

3. Replace 1,000 feet of transite pipe with eight-inch PVC on Southeast Graham Court to South Ora Street
4. Extend and eight-inch water main from corner of North 433 Road and Graffiti Road to 1521 Clayton Road
5. Replace four-inch water main with a six-inch water main from 6 South Adair Street to SE First Street
6. Implementation Phase I (Billing Zone 3) AMI (Automated Meter Infrastructure) Solution with UTS (Utility Technology Services, Inc.)
7. Extend six-inch water main on Carbide Road
8. Extend 1,800 feet of six-inch water main to 305 North Gaither Road
9. Extend 300 feet of eight-inch water main for a fire plug and future growth North of 1700 North Highway 69
10. Extend 600 feet of two-inch PVC water line to finish the loop at North Maple Street and Helton Lane
11. Extend two-inch PVC water line from 2217 to 2209 South Elliott and set two $\frac{3}{4}$ inch meters

WASTEWATER COLLECTION SYSTEM

Fiscal Year Ending June 30, 2024

1. New construction and replacement projects in the Wastewater Collection Department funded out of operating funds in the amount of \$23,450
2. Upgraded eight-inch sewer line between 8th Street and 9th Street and between Adair Street and Wood Street
3. Extended six-inch sewer line and relay at 10 South Bailey Street

Proposed Projects for Fiscal Year Ending June 30, 2025

1. Upgrade lift station at B & H Corner
2. Upgrade lift station on Ni-Pak Road
3. Upgrade lift station at Elks Lodge and include a natural gas generator
4. Implement SCADA System to all lift stations

5. Install natural gas generator at Southridge Lift Station
6. Upgrade eight-inch sewer line between 8th Street and 9th Street and Wood Street and Jackson Street
7. Certified application of OBIC Armor 1000, aromatic polyuria coating system in approximately 12 to 14 brick manholes throughout the system

WASTEWATER TREATMENT PLANT

Fiscal Year Ending June 30, 2024

1. The Wastewater Treatment Plant major repairs and replacement of equipment are funded from the \$0.005 Sales Tax Reserve Capital Improvement Account.
2. Added an additional department truck (Unit 17A) for the regular delivery of environmental protection samples
3. Upgraded the 500 kW Generac diesel generator at the wastewater treatment plant
4. Upgraded the chlorine contact basin flow monitoring and control of the chlorine and sulfur dioxide by R. W. Vaught Technical Services
5. Upgraded one of three 9th Street lift station plant pumps
6. Upgraded two fueling systems at the wastewater treatment plant, which included excavation, removal, disposal, and backfill of underground storage tanks; provided soil samples, closure report as required by the Oklahoma Corporation Commission, and the installation and piping of two (2) above ground storage tanks

Proposed Projects for Fiscal Year Ending June 30, 2025

1. Upgrade fueling system at the 9th Street lift station. Work to include, but not be limited to excavation, removal, disposal and backfill of the underground storage tank; provide soil samples, closure report as required by the Oklahoma Corporation Commission, and the installation and piping of an above ground storage tank
2. Upgrade Headworks at the Wastewater Treatment Plant
3. Renovation of SE 9th Street Lift Station and Lagoons
4. Insall generator at the Wastewater Treatment Plant
5. Upgrade the drive pumps at SE Ninth Street Lift Station to variable frequency drive

6. Upgrade piping to flow equalization basin while removing sludge and cleaning out trees/shrubs around and inside flow equalization basin

ELECTRIC DEPARTMENT

Fiscal Year Ending June 30, 2024

1. New construction and replacement projects in the Electric Department funded out of operating funds in the amount of \$398,258
2. Built new service to Phase I West 530 luxury apartments near “The District”
3. Built new residential service and installed a new 25 KVA transformer for 3685 NE First Street
4. Replaced #2 UG primary with 1/0 in the 400 block of North Oklahoma Street
5. Built new service to storage buildings behind JL’s Barbecue
6. Built new three phase primary service to 5377 South Mill
7. Set 25 KVA transformer and a 30’ pole for a new service extension to 4444 NE First Street
8. Reconducted new (4/0) three phase from 700 North Elliott Street to City of Pryor Creek P.A.L.S. Animal Shelter
9. Built new 4/0 three phase from P.A.L.S. Animal Shelter to 1700 North Highway 69
10. Built Phase I of new secondary for lighting at the soccer complex on North Gaither Road

Proposed projects for Fiscal Year Ending 30 June 2025

1. Build new three phase to Cherokee Nation Head Start and 530 Apartments at ”The District”
2. Build new service to Roosevelt Crossing addition
3. Build new three phase primary service at 4489 S Mill Street
4. Build new three-phase overhead primary on North 433 Road from Clayton Road to Old Airport Road
5. Build Phase II of new secondary for lighting at the soccer complex on North Gaither Road
6. Reconduct 4/0 feeder extension on Clayton Road from NE Fifth Street to North Gaither Road

7. Build new service into The Meadows at Stonegate Phase II and assembling double meter sets for future installation
8. Implementation of AMI (Automated Meter Infrastructure) solution
9. Install transformers for two (2) new Quadraplexes at 1220 Se Ninth Street
10. Build new service to Phase II of West 530 Luxury Apartments near “The District”
11. Build new electric service to new football field at 1251 SE Ninth Street

CITY OF PRYOR CREEK, OKLAHOMA
STATEMENT OF NET POSITION
JUNE 30, 2024

	Governmental Activities	Business-type Activities	Total
ASSETS			
Current Assets:			
Cash	\$ 6,445,816	\$ 2,219,580	\$ 8,665,396
Taxes receivable	1,599,121	117,409	1,716,530
Accounts receivable (net)	--	2,123,638	2,123,638
Accounts receivable from intra-government	<u>341,276</u>	<u>2,198</u>	<u>343,474</u>
Total current assets	<u>8,386,213</u>	<u>4,462,825</u>	<u>12,849,038</u>
Noncurrent assets:			
Restricted assets:			
Cash, including time deposits	796,291	11,920,744	12,717,035
Taxes receivable	211,337	234,819	446,156
Net pension assets	148,916	--	148,916
Capital assets (net)	55,955,632	35,449,537	91,405,169
Inventory	<u>--</u>	<u>2,162,730</u>	<u>2,162,730</u>
Total noncurrent assets	<u>57,112,176</u>	<u>49,767,830</u>	<u>106,880,006</u>
Total assets	<u>65,498,389</u>	<u>54,230,655</u>	<u>119,729,044</u>
Deferred outflows of resources related to pensions	<u>4,479,309</u>	<u>--</u>	<u>4,479,309</u>
LIABILITIES			
Current liabilities			
Accounts payable	550,724	1,234,006	1,784,730
Accrued expenses	180,695	110,673	291,368
Notes payable, current portion	1,086,618	141,227	1,227,845
Payable to intra-government	339,763	3,711	343,474
Accrued compensated absences	<u>201,081</u>	<u>266,333</u>	<u>467,414</u>
Total current liabilities	<u>2,358,881</u>	<u>1,755,950</u>	<u>4,114,831</u>
Payable from restricted assets			
Accrued expenses	<u>121,363</u>	<u>--</u>	<u>121,363</u>
Total	<u>2,480,244</u>	<u>1,755,950</u>	<u>4,236,194</u>
Noncurrent liabilities:			
Customer deposits payable	--	1,114,130	1,114,130
Notes and bonds payable, long-term portion	10,238,104	759,537	10,997,641
Net pension liability	<u>3,987,322</u>	<u>--</u>	<u>3,987,322</u>
Total noncurrent liabilities	<u>14,225,426</u>	<u>1,873,667</u>	<u>16,099,093</u>
Total liabilities	<u>16,705,670</u>	<u>3,629,617</u>	<u>20,335,287</u>
Deferred inflows of resources			
Deferred amounts related to pensions	<u>2,477,395</u>	<u>--</u>	<u>2,477,395</u>
NET POSITION			
Invested in capital assets, net of related debt	44,630,910	35,429,785	80,060,695
Restricted for:			
Capital projects and emergencies	3,488,463	9,038,043	12,526,506
Debt service	886,266	--	886,266
Other	1,491,259	2,003,390	3,494,649
Unrestricted	<u>297,735</u>	<u>4,129,820</u>	<u>4,427,555</u>
Total net position	<u>\$ 50,794,633</u>	<u>\$ 50,601,038</u>	<u>\$ 101,395,671</u>

CITY OF PRYOR CREEK, OKLAHOMA
STATEMENT OF ACTIVITIES
YEAR ENDED JUNE 30, 2024

Statement 2

		Program Revenues			
<u>Expenses</u>	<u>Charges for Services</u>	<u>Operating Grants and Contributions</u>	<u>Capital Grants and Contributions</u>	<u>Net (Expense) Revenue</u>	
Governmental activities					
General government					
Community Development	\$ 401,778	\$ --	\$ --	\$ --	
Planning and Zoning	59,063	--	--	(59,063)	
Mayor and Council	238,381	--	--	(238,381)	
City Clerk	370,789	--	--	(370,789)	
City Treasurer	26,265	--	--	(26,265)	
General Government	<u>996,200</u>	<u>144,197</u>	<u>109,997</u>	<u>(742,006)</u>	
Total general government	<u>2,092,476</u>	<u>144,197</u>	<u>109,997</u>	<u>(1,838,282)</u>	
Public safety and judiciary					
City Attorney	57,580	--	--	(57,580)	
Police	4,736,946	229,335	--	(4,269,293)	
Fire	2,661,404	77,754	--	(2,583,650)	
Civil Emergency Management	21,583	--	--	(21,583)	
Animal control	311,542	--	--	(311,542)	
Municipal Court	<u>55,223</u>	<u>--</u>	<u>--</u>	<u>(55,223)</u>	
Total public safety and judiciary	<u>7,844,278</u>	<u>307,089</u>	<u>--</u>	<u>(7,298,871)</u>	
Transportation					
Street	<u>2,097,501</u>	<u>--</u>	<u>--</u>	<u>(2,097,501)</u>	
Cultural, parks and recreation					
Library	644,704	768	14,627	(629,309)	
Cemetery	279,262	61,140	--	(218,122)	
Recreation	530,994	--	25,850	(505,144)	
Tourism	<u>103,373</u>	<u>--</u>	<u>--</u>	<u>(103,373)</u>	
Total cultural, parks and Recreation	<u>1,558,333</u>	<u>61,908</u>	<u>40,477</u>	<u>(1,455,948)</u>	
Total governmental activities	<u>13,592,588</u>	<u>513,194</u>	<u>150,474</u>	<u>(12,690,602)</u>	

**CITY OF PRYOR CREEK, OKLAHOMA
STATEMENT OF ACTIVITIES
YEAR ENDED JUNE 30, 2024**

	<u>Expenses</u>	<u>Program Revenues</u>		<u>Net (Expense) Revenue</u>
		<u>Charges for Services</u>	<u>Operating Grants and Contributions</u>	
Business-type activities:				
Utilities	16,276,069	16,598,756	18,978	--
Golf	660,354	739,109	--	--
Recreation Center	<u>1,366,257</u>	<u>471,437</u>	<u>--</u>	<u>--</u>
Total business-type activities	<u>18,302,680</u>	<u>17,809,302</u>	<u>18,978</u>	<u>--</u>
Total	<u>\$ 31,895,268</u>	<u>\$ 18,322,496</u>	<u>\$ 169,452</u>	<u>\$ 238,318</u>

CHANGES IN NET POSITION

	<u>Governmental Activities</u>	<u>Business-type Activities</u>	<u>Total</u>
Net (expense) /revenue	<u>\$(12,690,602)</u>	<u>\$(474,400)</u>	<u>\$(13,165,002)</u>
General Revenues			
Taxes:			
Sales tax	8,927,745	2,031,771	10,959,516
Use tax	1,209,052	--	1,209,052
Alcohol beverage tax	129,346	--	129,346
E-911 tax	9,254	--	9,254
Hotel/motel tax	106,540	--	106,540
Gasoline tax	16,967	--	16,967
Motor vehicle tax	69,805	--	69,805
Franchise taxes	71,811	--	71,811
Cigarette tax	67,221	--	67,221
Reimbursements	392,596	--	392,596
Investment income	189,555	425,195	614,750
Miscellaneous	20,222	128,002	148,224
Disposal of assets	6,800	17,087	23,887
Transfers	828,088	(828,088)	--
Expense - bonds	<u>(249,887)</u>	<u>--</u>	<u>(249,887)</u>
Total general revenues and transfers	<u>11,795,115</u>	<u>1,773,967</u>	<u>13,569,082</u>
Change in net position	(895,487)	1,299,567	404,080
Net position - beginning	<u>51,690,120</u>	<u>49,301,471</u>	<u>100,991,591</u>
Net position - ending	<u>\$ 50,794,633</u>	<u>\$ 50,601,038</u>	<u>\$101,395,671</u>

**CITY OF PRYOR CREEK, OKLAHOMA
BALANCE SHEET
GOVERNMENTAL FUNDS
JUNE 30, 2024**

	<u>General Fund</u>	<u>Street & Drainage Fund</u>	<u>PPWA Sinking Fund</u>	<u>Capital Improvements Fund</u>	<u>Other Governmental Funds</u>	<u>Total Governmental Funds</u>
ASSETS						
Cash	\$ 1,228,470	\$ 2,529,735	\$ 796,291	\$ 408,451	\$ 2,279,160	\$ 7,242,107
Taxes receivable	1,105,745	315,036	211,337	105,669	72,671	1,810,458
Due from other funds	<u>337,565</u>	<u>--</u>	<u>--</u>	<u>--</u>	<u>3,711</u>	<u>341,276</u>
Total assets	<u>\$ 2,671,780</u>	<u>\$ 2,844,771</u>	<u>\$ 1,007,628</u>	<u>\$ 514,120</u>	<u>\$ 2,355,542</u>	<u>\$ 9,393,841</u>
LIABILITIES						
Accounts payable	176,484	176,788	--	115,153	82,299	550,724
Accrued expenses	168,141	12,554	121,363	--	--	302,058
Due to other funds	2,198	--	--	--	337,565	339,763
Accrued comp. absences	<u>46,815</u>	<u>13,819</u>	<u>--</u>	<u>--</u>	<u>--</u>	<u>60,634</u>
Total liabilities	<u>393,638</u>	<u>203,161</u>	<u>121,363</u>	<u>115,153</u>	<u>419,864</u>	<u>1,253,179</u>
FUND BALANCES						
Restricted	--	2,641,610	886,265	289,910	1,884,627	5,702,412
Assigned	3,468	--	--	109,057	51,051	163,576
Unassigned	<u>2,274,674</u>	<u>--</u>	<u>--</u>	<u>--</u>	<u>--</u>	<u>2,274,674</u>
Total fund balance	<u>2,278,142</u>	<u>2,641,610</u>	<u>886,265</u>	<u>398,967</u>	<u>1,935,678</u>	<u>8,140,662</u>
Total liabilities and fund balances	<u>\$ 2,671,780</u>	<u>\$ 2,844,771</u>	<u>\$ 1,007,628</u>	<u>\$ 514,120</u>	<u>\$ 2,355,542</u>	<u>\$ 9,393,841</u>

**CITY OF PRYOR CREEK, OKLAHOMA
BALANCE SHEET
GOVERNMENTAL FUNDS
JUNE 30, 2024**

	<u>Total Governmental Funds</u>
Fund balance of governmental funds	\$ 8,140,662
Amounts reported for governmental activities in the Statement of net position are different because:	
Capital assets used in governmental activities are not financial resources and, therefore are not reported in the funds, net of accumulated depreciation of \$44,253,140	55,955,632
Portion of accrued compensated absences does not require current financial resources. Therefore, \$140,447 of total of \$201,081 of accrued compensated absences is not reported as a liability in government funds balance sheet	(140,447)
Other long-term assets are not available to pay for current period expenditures, and, therefore, are deferred in the funds:	
Pension related deferred outflows	4,479,309
Net pension assets	148,916
Certain liabilities are not due and payable in the current period from current financial resources, and, therefore, are not reported in the funds	
Net pension liability	(3,987,322)
Pension related deferred inflows	(2,477,395)
Long-term debt, net of prepaid loan principal	<u>(11,324,722)</u>
Net position of governmental activities	<u>\$ 50,794,633</u>

The issuance of long-term debt (e.g., bonds) provides current financial resources to governmental funds, while the repayment of the principal and long-term debt consumes the current financial resources of governmental funds. Neither transaction, however, has any effect on net position.

CITY OF PRYOR CREEK, OKLAHOMA
STATEMENT OF REVENUES, EXPENDITURES, AND CHANGES IN FUND BALANCES
GOVERNMENTAL FUNDS
YEAR ENDED JUNE 30, 2024

	General <u>Fund</u>	Street & Drainage <u>Fund</u>	PPWA Sinking <u>Fund</u>	Capital Improvement <u>Fund</u>	Other Governmental <u>Funds</u>	Total Governmental <u>Funds</u>
REVENUES						
Sales tax	\$ 5,079,430	\$ 1,760,869	\$ 1,219,063	\$ 609,532	\$ 258,851	\$ 8,927,745
Other taxes	1,405,619	86,772	--	--	115,794	1,608,185
Fines and forfeits	221,937	--	--	--	7,398	229,335
Licenses and permits	103,793	--	--	--	--	103,793
Franchise taxes	28,521	--	--	--	43,290	71,811
Fees and services	80,671	--	--	--	31,541	112,212
Interest	58,763	78,723	20,032	4,244	27,758	189,520
Reimbursements/asset sales/ loan proceeds	335,941	63,455	--	--	--	399,396
Miscellaneous	7,256	--	--	--	12,966	20,222
Grants and contributions	109,997	--	--	--	346,649	456,646
Total revenues	<u>7,431,928</u>	<u>1,989,819</u>	<u>1,239,095</u>	<u>613,776</u>	<u>844,247</u>	<u>12,118,865</u>
EXPENDITURES						
Current						
General government:						
Community Development	142,172	--	--	--	--	142,172
Planning and Zoning	3,046	--	--	--	--	3,046
Mayor and Council	238,381	--	--	--	--	238,381
City Clerk	362,024	--	--	--	--	362,024
City Treasurer	26,265	--	--	--	--	26,265
General Government	595,410	--	--	--	426,799	1,022,209
Total General Government	<u>1,367,298</u>	<u>--</u>	<u>--</u>	<u>--</u>	<u>426,799</u>	<u>1,794,097</u>
Public safety and judiciary:						
City Attorney	57,580	--	--	--	--	57,580
Police	4,261,404	--	--	--	6,129	4,267,533
Animal control	311,469	--	--	--	--	311,469
Fire	1,992,144	--	--	--	60,258	2,052,402
Civil Emergency Management	21,349	--	--	--	--	21,349
Municipal Court	55,863	--	--	--	--	55,863
Total Public Safety and Judiciary	<u>6,699,809</u>	<u>--</u>	<u>--</u>	<u>--</u>	<u>66,387</u>	<u>6,766,196</u>
Transportation						
Street	<u>--</u>	<u>938,080</u>	<u>--</u>	<u>--</u>	<u>--</u>	<u>938,080</u>

CITY OF PRYOR CREEK, OKLAHOMA
STATEMENT OF REVENUES, EXPENDITURES, AND CHANGES IN FUND BALANCES
GOVERNMENTAL FUNDS
YEAR ENDED JUNE 30, 2024

	General <u>Fund</u>	Street & Drainage <u>Fund</u>	PPWA Sinking <u>Fund</u>	Other Governmental <u>Funds</u>	PPWA Note Proceeds <u>Fund</u>	Total Governmental <u>Funds</u>
Cultural, Parks and Recreation						
Library	531,149	--	--	--	10,137	541,286
Cemetery	249,150	--	--	--	--	249,150
Recreation	422,642	--	--	--	--	422,642
Tourism	--	--	--	--	103,372	103,372
	<u>1,202,941</u>	<u>--</u>	<u>--</u>	<u>--</u>	<u>113,509</u>	<u>1,316,450</u>
Total cultural, Park and recreation						
Debt service						
Principal	--	--	850,399	204,812	--	1,055,211
Interest and other charges	--	--	251,488	13,194	--	264,682
Capital outlay	103,428	1,891,624	46,692	202,563	819,212	3,063,519
	<u>9,373,476</u>	<u>2,829,704</u>	<u>1,148,579</u>	<u>420,569</u>	<u>1,425,907</u>	<u>15,198,235</u>
Total expenditures						
Excess (deficiency) of revenues over expenditures	(1,941,548)	(839,885)	90,516	193,207	(581,660)	(3,079,370)
Other financing sources (uses)						
Transfers in	1,190,288	--	592	38,625	288,516	1,518,021
Transfer out	(77,141)	--	(5,992)	(256,924)	(344,764)	(684,821)
	<u>1,113,147</u>	<u>--</u>	<u>(5,400)</u>	<u>(218,299)</u>	<u>(56,248)</u>	<u>833,200</u>
Total other financing Sources (uses)						
Net change in fund balances	(828,401)	(839,885)	85,116	(25,092)	(637,908)	(2,246,170)
Fund balance – beginning	3,106,543	3,481,495	801,149	424,059	2,573,586	10,386,832
Fund balances – ending	<u>\$ 2,278,142</u>	<u>\$ 2,641,610</u>	<u>\$ 886,265</u>	<u>\$ 398,967</u>	<u>\$ 1,935,678</u>	<u>\$ 8,140,662</u>

CITY OF PRYOR CREEK, OKLAHOMA
STATEMENT OF REVENUES, EXPENDITURES, AND CHANGES IN FUND BALANCES
GOVERNMENTAL FUNDS
YEAR ENDED JUNE 30, 2024

Reconciliation of the change in fund balances - total government funds to the change in net position of governmental activities

Net change in fund balances - total governmental funds \$(2,246,170)

Amounts reported for governmental activities in the Statement of Activities are different because

Governmental funds report capital outlays as expenditures while governmental activities report depreciation expense to allocate those expenditures over the life of the assets:

Capital asset purchases capitalized	3,087,967
Capital assets disposed (net of accumulated depreciation)	(150,225)
Depreciation expense	<u>(2,443,833)</u>
	<u>\$ 493,909</u>

Governmental funds do not report long-term financing as revenues and report payments as expenditures while governmental activities report such payments as debt activities

Payment of long-term debt	1,055,211
Issuance of note	(28,920)

Some expense reported in the Statement of Activities do not require the use of current financial resources and therefore are not reported as expenditures in governmental funds:

Accrued compensated absences	(4,742)
------------------------------	----------

In the Statement of Activities, the cost of pension benefits earned net of employee contributions is reported as an element of pension expense. The Fund Financial Statements report pension contributions as expenditures.

(164,775)

Change in net position of governmental activities \$(895,487)

CITY OF PRYOR CREEK, OKLAHOMA
STATEMENT OF NET POSITION
PROPRIETARY FUNDS
JUNE 30, 2024

	<u>Business-type Activities - Enterprise Funds</u>			
	<u>Recreation Center</u>	<u>Golf Course Fund</u>	<u>Municipal Utility Department</u>	<u>Total</u>
ASSETS				
Current assets				
Cash	\$ 733,020	\$ 387,894	\$ 1,098,666	\$ 2,219,580
Taxes receivable	117,409	--	--	117,409
Accounts receivable	--	--	2,123,638	2,123,638
Due from other funds	--	--	2,198	2,198
Total current assets	<u>850,429</u>	<u>387,894</u>	<u>3,224,502</u>	<u>4,462,825</u>
Noncurrent assets				
Restricted assets				
Cash and cash equivalents	--	--	11,920,744	11,920,744
Taxes receivable	--	--	234,819	234,819
Inventory	--	--	2,162,730	2,162,730
Capital assets (net)	<u>4,785,543</u>	<u>728,662</u>	<u>29,935,332</u>	<u>35,449,537</u>
Total noncurrent assets	<u>4,785,543</u>	<u>728,662</u>	<u>44,253,625</u>	<u>49,767,830</u>
Total assets	<u>5,635,972</u>	<u>1,116,556</u>	<u>47,478,127</u>	<u>54,230,655</u>
LIABILITIES				
Current liabilities				
Accounts payable	205,518	30,364	998,124	1,234,006
Accrued expenses	9,980	3,862	96,831	110,673
Accrued compensated absences	7,666	5,356	253,311	266,333
Due other funds	--	--	3,711	3,711
Current portion of long-term debt	--	19,752	121,475	141,227
Total current liabilities	<u>223,164</u>	<u>59,334</u>	<u>1,473,452</u>	<u>1,755,950</u>
Non-current liabilities				
Customers' meter deposits (payable from restricted assets)	--	--	1,114,130	1,114,130
Notes payable	--	--	759,537	759,537
Total non-current liabilities	--	--	<u>1,873,667</u>	<u>1,873,667</u>
Total liabilities	<u>223,164</u>	<u>59,334</u>	<u>3,347,119</u>	<u>3,629,617</u>
NET POSITION				
Investment in capital assets, net of related debt	4,785,543	708,910	29,935,332	35,429,785
Restricted:				
Sales tax reserved for capital improvements	--	--	6,037,335	6,037,335
Charter required legal obligations	--	--	2,003,390	2,003,390
Property, plant and equipment and emergency and disaster	--	--	3,000,708	3,000,708
Unrestricted	<u>627,265</u>	<u>348,312</u>	<u>3,154,243</u>	<u>4,129,820</u>
Total net position	<u>\$ 5,412,808</u>	<u>\$ 1,057,222</u>	<u>\$ 44,131,008</u>	<u>\$ 50,601,038</u>

CITY OF PRYOR CREEK, OKLAHOMA
STATEMENT OF REVENUES, EXPENSES AND
CHANGES IN NET POSITION
PROPRIETARY FUNDS
FOR THE YEAR ENDED JUNE 30, 2024

	<u>Business-type Activities - Enterprise Funds</u>			
	<u>Recreation Center</u>	<u>Golf Course Fund</u>	<u>Municipal Utility Department</u>	<u>Total</u>
Operating revenues				
Utility charge	\$ --	\$ --	\$ 16,433,829	\$ 16,433,829
Utility taps	--	--	30,807	30,807
Penalties	--	--	134,120	134,120
Miscellaneous	--	--	128,002	128,002
Fee income	<u>471,437</u>	<u>739,109</u>	<u>--</u>	<u>1,210,546</u>
Total operating revenues	<u>471,437</u>	<u>739,109</u>	<u>16,726,758</u>	<u>17,937,304</u>
Operating expenses				
Purchased utilities	--	--	9,247,956	9,247,956
Personnel services	532,874	260,554	3,314,935	4,108,363
Personnel benefits	151,773	45,065	1,202,694	1,399,532
Materials and supplies	69,283	--	913,670	982,953
Other expenses	341,665	256,183	1,051,378	1,649,226
Bad debts expense	--	--	27,942	27,942
Depreciation expense	270,662	98,552	1,197,594	1,566,808
Less: expenses capitalized	<u>--</u>	<u>--</u>	<u>(700,023)</u>	<u>(700,023)</u>
Total operating expense	<u>1,366,257</u>	<u>660,354</u>	<u>16,256,146</u>	<u>18,282,757</u>
Net operating income (loss)	<u>(894,820)</u>	<u>78,755</u>	<u>470,612</u>	<u>(345,453)</u>
Nonoperating revenue (expense)				
Gain (loss) on asset disposal/				
Insurance reimbursement	--	19,556	(2,469)	17,087
Sales tax revenue	677,257	--	1,354,514	2,031,771
Investment income	30,332	7,282	387,581	425,195
Grants	--	--	18,987	18,978
Interest expense	<u>--</u>	<u>(694)</u>	<u>(19,229)</u>	<u>(19,923)</u>
Total nonoperating revenue (expenses)	<u>707,589</u>	<u>26,144</u>	<u>1,739,375</u>	<u>2,473,108</u>
Net income (loss) before contributions and transfers	<u>(187,231)</u>	<u>104,899</u>	<u>2,209,987</u>	<u>2,127,655</u>
Operating transfers in (out)	<u>(58,000)</u>	<u>5,112</u>	<u>(775,200)</u>	<u>(828,088)</u>
Change in net position	<u>(245,231)</u>	<u>110,011</u>	<u>1,434,787</u>	<u>1,299,567</u>
Net position - beginning of year	<u>5,658,039</u>	<u>947,211</u>	<u>42,696,221</u>	<u>49,301,471</u>
Net position - end of year	<u>\$ 5,412,808</u>	<u>\$ 1,057,222</u>	<u>\$ 44,131,008</u>	<u>\$ 50,601,038</u>

CITY OF PRYOR CREEK, OKLAHOMA
STATEMENT OF CASH FLOWS
PROPRIETARY FUNDS
FOR THE YEAR ENDED JUNE 30, 2024

	<u>Business-type Activities - Enterprise Funds</u>			
	<u>Recreation Center</u>	<u>Golf Course Fund</u>	<u>Municipal Utility Department</u>	<u>Total</u>
Cash flows from operating activities				
Receipts from customers	\$ 471,437	\$ 739,109	\$ 16,525,827	\$ 17,736,373
Payments to suppliers	(219,984)	(247,842)	(12,821,304)	(13,289,130)
Payments to employees and benefits	(680,084)	(304,153)	(3,287,730)	(4,271,967)
Payments capitalized	--	--	700,023	700,023
Receipts over refunds of customer meter deposits	<u> --</u>	<u> --</u>	<u> 27,205</u>	<u> 27,205</u>
Net cash provided (used) by operating activities	<u>(428,631)</u>	<u> 187,114</u>	<u> 1,144,021</u>	<u> 902,504</u>
Cash flows from noncapital financing activities				
Operating subsidies and transfers from (to) other funds	(58,000)	5,112	(775,200)	(828,088)
Retirement of non-capital related debt	--	--	(118,988)	(118,988)
Interest on non-capital debt	<u> --</u>	<u> --</u>	<u>(19,229)</u>	<u>(19,229)</u>
Net cash provided (used) by Non-capital financing activities	<u>(58,000)</u>	<u> 5,112</u>	<u>(913,417)</u>	<u>(966,305)</u>
Cash flows from capital and related financing activities				
Sales tax receipts	683,900	--	1,367,799	2,051,699
Purchases of capital assets	(472,095)	(51,224)	(2,333,029)	(2,856,348)
Repayment of long-term debt	--	(29,844)	--	(29,844)
Sale of capital assets	--	19,556	15,100	34,656
Grant proceeds	--	--	18,978	18,978
Interest expense	<u> --</u>	<u>(694)</u>	<u> --</u>	<u>(694)</u>
Net cash provided (used) by capital and related financing activities	<u> 211,805</u>	<u>(62,206)</u>	<u>(931,152)</u>	<u>(781,553)</u>
Cash flows from investing activities				
Interest and dividends	<u> 30,332</u>	<u> 7,282</u>	<u> 387,581</u>	<u> 425,195</u>
Net cash provided (used) by investing activities	<u> 30,332</u>	<u> 7,282</u>	<u> 387,581</u>	<u> 425,195</u>
Net increase (decrease) in cash and cash equivalents	(244,494)	137,302	(312,967)	(420,159)
Cash balance - beginning of year	<u> 977,514</u>	<u> 250,592</u>	<u> 13,332,377</u>	<u> 14,560,483</u>
Cash balance - end of year	<u>\$ 733,020</u>	<u>\$ 387,894</u>	<u>\$ 13,019,410</u>	<u>\$ 14,140,324</u>
Cash, including time deposits	733,020	387,894	1,098,666	2,219,580
Restricted cash, including time deposits	<u> --</u>	<u> --</u>	<u> 11,920,744</u>	<u> 11,920,744</u>
Total cash and cash equivalents, end of year	<u>\$ 733,020</u>	<u>\$ 387,894</u>	<u>\$ 13,019,410</u>	<u>\$ 14,140,324</u>

**CITY OF PRYOR CREEK, OKLAHOMA
STATEMENT OF CASH FLOWS
PROPRIETARY FUNDS**

	<u>Business-type Activities - Enterprise Funds</u>			
	<u>Recreation Center</u>	<u>Golf Course Fund</u>	<u>Municipal Utility Department</u>	<u>Total</u>
Reconciliation of operating income (loss) to net cash provided (used) by operating activities)				
Operating income (loss)	\$(894,820)	\$ 78,755	\$ 470,612	\$(345,453)
Adjustments to reconcile operating income to net cash provided (used) by operating activities:				
Cash flows reported in other categories:				
Depreciation expense	270,662	98,552	1,169,652	1,538,866
Bad debt expense	--	--	27,942	27,942
Change in assets and liabilities				
receivables, net	--	--	(194,961)	(194,961)
Inventories	--	--	(340,954)	(340,954)
Accounts and other payables	(190,468)	10,439	(60,083)	140,824
Customer meter deposits payable	--	--	44,608	44,608
Accrued expenses	<u>5,059</u>	<u>(632)</u>	<u>27,205</u>	<u>31,632</u>
	<u>\$(428,631)</u>	<u>\$ 187,114</u>	<u>\$ 1,144,021</u>	<u>\$ 902,504</u>

Noncash investing, capital and financing activities:

For the fiscal year ending June 30, 2023, assets with a cost of \$308,511 and accumulated depreciation of \$294,365 were scrapped or surplusd. A gain of \$83,814 resulted for the fiscal year on sales of \$97,960.

MUB wrote off assets with a cost of \$32,001 and accumulated depreciation of \$302,432 that was replaced or scrapped per department policy. A loss on asset disposal of \$2,469 resulted from sales of \$15,100 for the fiscal year ending June 30, 2024.

CITY OF PRYOR CREEK, OKLAHOMA
NOTES TO BASIC FINANCIAL STATEMENTS
TABLE OF CONTENTS

NOTE 1. SUMMARY OF SIGNIFICANT ACCOUNTING POLICIES

- A. Financial Reporting Entity
- B. Basis of Presentation
- C. Measurement Focus and Basis of Accounting
- D. Assets, Liabilities, and Equity
- E. Revenues, Expenditures, and Expenses

NOTE 2. STEWARDSHIP, COMPLIANCE, AND ACCOUNTABILITY

- A. Fund Accounting Requirements
- B. Deposits and Investments Laws and Regulations
- C. Revenue Restrictions
- D. Debt Restrictions and Covenants
- E. Fund Equity Restrictions

NOTE 3. DETAIL NOTES ON TRANSACTION CLASSES/ACCOUNTS

- A. Cash and Investments
- B. Restricted Assets
- C. Accounts Receivable
- D. Capital Assets
- E. Inventory
- F. Accounts Payable
- G. Long-term Debt
- H. Accrued Compensated Absences
- I. Due to/from Other Funds - Operating and Capital Transfers
- J. Fund Equity

NOTE 4. OTHER NOTES

- A. Employee Pension
- B. Risk Management
- C. Subsequent Events

CITY OF PRYOR CREEK, OKLAHOMA
NOTES TO BASIC FINANCIAL STATEMENTS
JUNE 30, 2024

NOTE 1. SUMMARY OF SIGNIFICANT ACCOUNTING POLICIES

The City of Pryor Creek was created in 1871 and operates under a strong Mayor/Council form of government. The City's major operations include public safety, (Police, fire and civil defense), recreation, parks and library, provision and maintenance of streets and drainage, utility service (electric, gas, water and sewer), and general administrative services. In addition, the City exercises sufficient control over other governmental agencies that are included as part of the City's reporting entity.

The City complies with generally accepted accounting principles (GAAP). GAAP includes all relevant Governmental Accounting Standards Board (GASB) pronouncements. In the government-wide financial statements and the fund financial statements for the proprietary funds, Financial Accounting Standards Board (FASB) pronouncements and Accounting Principles Board (APB) opinions issued on or before November 30, 1989, have been applied unless those pronouncements conflict with or contradict GASB pronouncements, in which case, GASB prevails. For enterprise funds, GASB Statement Nos. 20 and 34 provide the City the option of electing to apply FASB pronouncements issued after November 30, 1989. The City has elected not to apply those pronouncements. The accounting and reporting framework and the more significant accounting policies are discussed in subsequent subsections of this Note. The City was required to implement the new financial reporting requirements of GASB Statement Nos. 33 and 34 for the year ended June 30, 2003. Effective for the year ended June 30, 2006, the City is reporting all infrastructure. See Notes 3.D and 3.J.

1.A. FINANCIAL REPORTING ENTITY

The City's financial reporting entity comprises the following:

Primary Government:	City of Pryor Creek
Blended Component Unit:	Pryor Public Works Authority
Blended Other Units	County Wide Fire Department Fund

In determining the financial reporting entity, The City complies with the provisions of GASB Statement No. 14, "The Financial Reporting Entity," and includes all component units of which the City appointed a voting majority of the units' board; the City is either able to impose its will on the unit or a financial benefit or burden relationship exists.

Blended Component Unit

A blended component unit is a separate legal entity that meets the component unit criteria described above and whose governing body is the same or substantially the same as the City Council or the component unit provides services entirely to the City. The component unit's funds are blended into those of the City's by appropriate activity type to compose the primary government presentation.

Discretely Presented Component Units

Discretely presented component units are separate legal entities that meet the component unit criteria described above but do not meet the criteria for blending. Currently, the City has no discretely presented component units.

Blended Component Unit

<i>Component Unit</i>	<i>Brief Description/Inclusion Criteria</i>	<i>Reporting</i>
Pryor Public Works	The Authority is utilized for the purpose of entering into a long-term contract providing the Citizens of Pryor Creek with trash services. Its major source of income is franchise fees from such contract.	Special Revenues

Blended Other Units

A countywide sales tax was passed, effective January 1, 2003, for the purpose of providing revenues to the various fire departments of Mayes County. The sales tax receipts, which began in March, 2003 and are equally divided among the fire departments, is administered by the County which maintains a fund for each fire department, including that of the City of Pryor Creek. Purchases against the funds can only be initiated by each fire department, sometimes requiring its governing board approval.

Other Units by Reference

The Pryor Creek Economic Development Authority is included in this report. However, since the Authority has no assets, liabilities (only non-commitment debt to the City and the Authority), revenues or expenditures, it is included only by reference and explanation in the notes to the financial statements. The original amount of the debt was \$2,356,000.

1.B. BASIS OF PRESENTATION

Government-wide Financial Statements:

The Statement of Net position and Statement of Activities display information about the reporting government as a whole. They include all funds of the reporting entity. The statements distinguish between governmental and business-type activities. Governmental activities generally are financed through taxes, intergovernmental revenues, and other non-exchange revenues. Business-type activities are financed in whole or in part by fees charged to external parties for goods or services.

Fund Financial Statements:

Fund financial statements of the reporting entity are organized into funds, each of which is considered to be separate accounting entities. Each fund is accounted for by providing a separate set of self-balancing accounts that constitute its assets, liabilities, fund equity, revenues, and expenditure/expenses. Funds are organized into two major categories: governmental and proprietary. An emphasis is placed on major funds within the governmental and proprietary categories. A fund is considered major if it is the primary operating fund of the City or meets the following criteria:

- a. Total assets, liabilities, revenues, or expenditures/expenses of that individual governmental or enterprise fund are at least 10 percent of the corresponding total for all funds of that category or type; and
- b. total assets, liabilities, revenues, or expenditures/expenses of the individual governmental fund or enterprise fund are at least 5 percent of the corresponding total for all governmental and enterprise funds combined.

The funds of the financial reporting entity are described below:

Governmental Funds

General Fund

The General Fund is the primary operating fund of the City and always classified as a major fund. It is used to account for all activities except those legally or administratively required to be accounting for in other funds.

Special Revenue Funds

Special Revenue Funds are used to account for the proceeds of specific revenue sources that are either legally or council restricted to expenditures for certain purposes.

Capital Project Funds

The Capital Project Funds are used to account for resources restricted for the acquisition or construction of specific capital projects or items. All capital project funds were created by Council action and derive their revenues as a result of Council action. Accordingly, the City Council can change or eliminate these funds by vote.

Debt Service Fund

The Debt Service Fund accounts for the accumulation of financial resources for the payment of interest and principle on the general long-term debt of the City other than debt service payments made by other funds. This fund receives revenues from a 1/2 cent sales tax until the general obligation bonds are fully paid. Although not anticipated, the City may assess a property tax if such sales tax is insufficient.

Proprietary Fund

Enterprise Fund

Enterprise funds are used to account for business-like activities provided to the general public. These activities are financed primarily by user charges and the measurement of financial activity focuses on net income measurement similar to the private sector. The Municipal Utility Department, Golf Course Fund and the Recreation Center constitute the Enterprise Funds. Beginning in June, 2023 the Swimming Pool was transferred out of the General Fund and became an Enterprise Fund. However, it was transferred back to the General Fund in the fiscal year ending June 30, 2024.

Major and Non-major Funds

The funds are further classified as major or non-major as follows:

Fund	Brief Description
Major:	
General	See above for description
Special Revenue Fund Street & Drainage	Accounts for revenues and expenditures of maintaining, improving and extending streets and drainage
PPWA Sinking Fund	Accounts for sales tax revenues and debt service expenditures for 2011 bonds

Proprietary Fund:	
Municipal Utility Board	Accounts for activities of providing electric, water,
Recreation Center Cash Fund	Charges for membership and services for use of the facilities and personnel in addition to receiving ¼ of 1 cent sales tax. The facility opened in March, 2009.
Golf Course Fund	Accounts for revenues and expenses of municipally run course.
Non-major:	
Special Revenue Funds:	
E-911	Accounts for revenues and expenditures of E-911 service that is legally restricted for public safety use.
Countywide Fire Department	See above for description.
Cemetery Care	Accounts for 25 percent of cemetery revenue restricted by State law for cemetery capital improvements.
Cemetery Care Interest Fund	Interest on cemetery care fund designated for cemetery operations.
Seizures	Police seizures for use of police department.
Library	Accounts for grants and contributions specifically for the library.
Donations and Earmarked Monies	Accounts for donations and grants for specific projects or specific purposes.
Public Works Authority	See above for description.
Hotel and Motel Tax	Accounts for revenues of hotel/motel tax restricted by local ordinance for the promotion of conventions and tourism.

Fee-in-Lieu	Accounts for funds deposited with the City by third parties for drainage projects caused by real estate development.
Police Cash Fund	Revenues consist of \$10 for each police fine to be used exclusively for the Police Department
Debt Service Fund	See above for description.
Capital Project Funds:	
Capital Outlay	Accounts for 1/8 of one cent sales tax dedicated for capital outlay. Cannot be changed without a vote of the people.
Capital Outlay	Although initially set up to fund the purchase of a fire truck Reserve in 2000, it has now essentially become a capital outlay fund for the fire department. Revenues consist of outside fire runs, fire subscriptions and grants for the fire department.
Real Property Acquisition	Created by the Council to accumulate funds for additions and improvements to land and buildings. Although at one time, this fund was allocated 1/10 of 1 cent sales tax, this fund has no designated source of income.
Library Building	Accounts for donations to add on to the existing library.
PPWA Bond Proceeds	Accounts for bonds proceeds to construct a new City Hall and for street improvements

The Municipal Utility Department was created by the Charter for the City of Pryor Creek, Oklahoma in January, 1951. The Department operates under the Utility Board consisting of five members. Vacancies in the membership of the Utility Board are filled by appointment by the remaining members of the Board subject to the approval of the City Council. The Department's operations consist of providing electrical, gas, water and sewage disposal service to the citizens of the City of Pryor Creek. All revenues received are dedicated by Charter as follows:

First, revenues are to be used for the payment of operating expenses, expenses incidental to the running of new services and the installation of new meters without major extension of lines, cost of minor extensions of lines and cost of replacements due to obsolescence.

Secondly, the Board is authorized to set aside, out of its revenues (reduced by encumbrances), a reserve for depreciation, replacement of obsolete or worn-out property, machinery, and equipment and to provide an emergency fund in cases of destruction or injury to utility properties. However, the funding for such reserve cannot exceed 20 percent of the net profits of the Utility Department for the year.

Third, after application of the foregoing, any surplus revenues shall be applied first to the current interest and accruals in the sinking fund of the City of Pryor Creek and thereafter transferred to the general fund of the City of Pryor Creek.

Legal counsel has ruled that if sufficient funding is otherwise available for the sinking fund, then such surplus revenues may go directly to the general fund.

1.C. MEASUREMENT FOCUS AND BASIS OF ACCOUNTING

Measurement focus is a term used to describe "which" transactions are recorded within the various financial statements. Basis of accounting refers to "when" transactions are recorded regardless of the measurement focus applied.

Measurement Focus

On the government-wide Statement of Net Position and the Statement of Activities, both governmental and businesslike activities are presented using the economic resources measurement focus as defined in item b. below.

In the fund financial statements, the "current financial resources" measurement focus or the "economic resources" measurement focus is used as appropriate:

- a. All governmental funds utilize a "current financial resources" measurement focus. Only current financial assets and liabilities are generally included on their balance sheets. Their operating statements present sources and uses of available spendable financial resources during a given period. These funds use fund balance as their measure of available spendable financial resources at the end of the period.
- b. The proprietary fund utilizes an "economic resources" measurement focus, except for sales tax revenues which are recognized on a "current financial resources" measurement by the Municipal Utility Department. The accounting objectives of this measurement focus are the determination of operating income, changes in net position (or cost recovery), financial position, and cash flows. All assets and liabilities (whether current or noncurrent) associated with their activities are reported. Proprietary fund equity is classified as net position.

Basis of Accounting

The City implemented a new financial reporting model, as required by the provisions of GASB Statement No. 34, *Basic Financial Statements - and Management's Discussion and Analysis - for State and Local Governments*, as of June 30, 2003. Beginning with the year ended June 30, 2006, all infrastructure is reflected on the Statement of Net Position. Prior to then only additions to infrastructure for the years ended June 30, 2003, 2004 and 2005 were reflected on such statements. See Notes 3.D and 3.J pertaining to the capitalization of infrastructure in the current year.

In the government-wide Statement of Net Position and Statement of Activities, both governmental and businesslike activities are presented using the accrual basis of accounting. Under the accrual basis of accounting, revenues are recognized when earned and expenses are recorded when the liability is incurred or economic asset used. Revenues, expenses, gains, losses, assets, and liabilities resulting from exchange and exchange-like transactions are recognized when the exchange takes place. Specifically, taxes received in July and August after the year end are accrued when such taxes pertain to the period being reported.

In the fund financial statements, governmental funds are also presented on the modified accrual basis of accounting. Under this modified accrual basis of accounting, revenues are recognized when "measurable and available". Licenses and permits, fines and forfeits, and miscellaneous revenues are recorded as revenues when received in cash. Sales and other taxes, franchise taxes, grants and investment earnings are recorded when earned. Grant receivables are recognized when expenditures are incurred that are to be reimbursed. Expenditures are recognized in the accounting period in which the fund liability is incurred, if measurable, except expenditures for debt services, prepaid expenses, and other long-term obligations which are recognized when paid.

Proprietary funds utilize the accrual basis of accounting. Under the accrual basis of accounting, revenues are recognized when earned and expenses are recorded when the liability is incurred or economic asset used.

Budget Basis of Accounting

Formal budgetary accounting is employed as a management control for the governmental funds of the City. Annual operating budgets are adopted each fiscal year for most funds. The basis of accounting for budgetary purposes for all funds is the modified accrual, i.e., revenues are recognized when received and expenditures are recognized when encumbered. The Enterprises Funds of the golf course and Municipal Utility Department also adopt budgets and revenues are recognized when earned and billed and expenditures are recognized when incurred.

The budget method authorized by Oklahoma Statute adopted by the City for its general fund places a limit on the amount that can be budgeted. The amount to be budgeted for the next fiscal year is the unreserved fund balance at the end of the fiscal year plus 90% of its revenues for the year just ended. However, the Municipal Utility Department, an Enterprise Fund, annually budgets an amount to remit to the City's general fund. The budgeted amount, not 90% of the amount remitted for the year then ended, is utilized in preparing the general fund's budget. All unencumbered budget appropriations, except project budgets, lapse at the end of each fiscal year.

1.D. ASSETS, LIABILITIES, AND EQUITY

Interfund Receivables and Payables

During the course of operations, numerous transactions occur between individual funds that may result in amounts owed between funds. Those related to goods and services type transactions are classified as "due to and from other funds." See Note 3.I. for details of interfund transactions, including receivables and payables at year end.

Receivables

In the government-wide statements, receivables consist of all revenues earned at year-end and not yet received.

The Municipal Utility Department is the only fund that has receivables that are essentially subject to bad debts. An allowance for uncollectible accounts has not been established, as is more fully explained in Note 3.C. Such receivables consist of utility charges to customers. The other proprietary fund, the golf course, has no receivables.

Inventories

The Municipal Utility Department is the only fund that has inventory in the financial statements. Such inventory is generally for repairs and improvements to the system and is classified as a noncurrent asset.

Fixed Assets

The accounting treatment over property, plant, and equipment (fixed assets) depends on whether the assets are used in governmental fund operations or proprietary fund operations and whether they are reported in the government-wide or fund financial statements.

Government-wide statements

In the government-wide financial statements, fixed assets are accounted for as capital assets. All fixed assets are valued at historical cost, or estimated historical cost if actual is unavailable, except for donated fixed assets which are recorded at their estimated fair value at the date of donation.

As of June 30, 2006 and later years, the governmental funds' infrastructure assets have been capitalized. Up to then, infrastructure was capitalized on a prospective basis for the years ending June 30, 2003, 2004 and 2005.

Depreciation of all exhaustible fixed assets is recorded as an allocated expense in the Statement of Activities, with accumulated depreciation reflected in the Statement of Net Position. Depreciation is provided over the assets' estimated useful lives using the straight-

line method of depreciation. The range of estimated useful lives by type of asset is as follows:

	<u>Governmental</u>	<u>Proprietary</u>
Buildings	25 - 50 years	20 - 40 years
Machinery and Equipment	3 - 20 years	5 - 10 years
Utility System	25 - 50 years	7 - 100 years
Infrastructure	13 - 160 years	

Because certain system additions for the Municipal Utility Department are actually replacements of old system assets, an estimate has been made to reduce the value of the system by the amount of the replaced assets. An estimate of 40% of current year utility system additions are removed, along with applicable accumulated depreciation, from appropriate utility system accounts (gas, electric, water, sewer). The oldest assets recorded are the first retired.

Fund Financial Statements

In the fund financial statements, fixed assets used in governmental fund operations are accounted for as capital outlay expenditures of the governmental fund upon acquisition. Fixed assets used in proprietary fund operations are accounted for the same as in the government-wide statements.

Restricted Assets

Restricted assets include cash and investments of the proprietary fund that are legally restricted as to their use. The primary restricted assets are related to charter and third party required reserves and utility meter deposits.

Long-term Debt

The accounting treatment of long-term debt depends on whether the assets are used in governmental fund operations or proprietary fund operations and whether they are reported in the government-wide or fund financial statements.

All long-term debt to be repaid from governmental and business-type resources are reported as liabilities in the government-wide statements. The long-term debt consists primarily of bonds and leases payable, accrued compensated absences, and customer meter deposits.

Long-term debt for governmental funds is not reported as liabilities in the fund financial statements. The debt proceeds are reported as other financing sources and payment of principal and interest reported as expenditures. The accounting for proprietary fund is the same in the fund statements as it is in the government-wide statements.

Compensated Absences

The City's policies regarding vacation and other compensated time off permit employees to accumulate earned but unused time off. The liability for these compensated absences is recorded as long-term debt in the government-wide statements. The current portion of this debt is estimated based on historical trends. In the fund financial statements, governmental funds report only the compensated absence liability payable from expendable available financial resources, while the proprietary funds report the liability as it is incurred.

Equity Classifications

Government-wide Statements

Equity is classified as net position and displayed in three components:

- a. Invested in capital assets, net of related debt - consists of capital assets including restricted capital assets, net of accumulated depreciation and reduced by the outstanding balances of any bonds, mortgages, notes, or other borrowings that are attributable to the acquisition, construction, or improvement of those assets.
- b. Restricted net position - Consists of net position with constraints placed on the use either by (1) external groups such as creditors, grantors, contributors, or laws or regulations of other governments; or (2) law through constitutional provisions or enabling legislation.

The Municipal Utility Department requires meter deposits for utility services. Such deposits are retained until services are discontinued. At that time, the deposits are applied first to any outstanding balances owed by the customers and the excess, if any, is refunded. No interest is paid on the deposits.

- c. Assigned net position - All net position that do not meet any of the definitions and are for a specific purpose
- d. Unassigned - All net position that do not meet any of the definitions and can be used for any purposes. Represents the net position of the General Fund.
- e. Unrestricted net position - All other net position of business-type activities that do not meet the definition of "restricted" or "invested in capital assets, net of related debt."

Fund Statements

Governmental fund equity is classified as fund balance. Fund balance is further classified as assigned and unassigned, with unreserved further split between designated and undesignated. Proprietary fund equity is classified the same as in the government-wide statements. See Note 3.G. for additional disclosures.

1.E. REVENUES, EXPENDITURES, AND EXPENSES

Sales Tax

The City levies a 4.000 cent sales tax. The sales tax is collected by the Oklahoma Tax Commission and remitted to the City in the month following receipt by the Tax Commission. The Tax Commission receives the sales tax approximately one month after collection by vendors. The sales tax is allocated to the various funds by ordinance:

	<u>Effective</u> <u>7/1/2018</u>	<u>Effective</u> <u>1/1/2023</u>
General Fund	1.875	1.875
Street and Drainage	.650	.650
Municipal Utility Department	.500	.500
Capital Outlay	.225	.225
Recreation Center Cash Fund	.250	.250
Sinking Fund - Bonded Indebtedness	.500	.450
Main Street Fund	<u>.000</u>	<u>.050</u>
	<u>4.000</u> cents	<u>4.000</u> cents

The sales tax is recorded in the various funds with the exception of the sales tax for the Municipal Utility Department which is recorded in the General Fund and transferred to the Municipal Utility Department. The sales tax in the Municipal Utility Department is restricted as discussed in Note 3.J.

Use Tax

The City levies a 4.000 use tax on personal property purchased outside the city limits but stored, used, or consumed within the city. The use tax is collected by the Oklahoma Tax Commission and remitted to the City in the month following receipt by the Tax Commission, which is one month after the tax is received from the vendors. Effective for use tax earned in December 2009 and received in February, 2010, the use tax was allocated to the General Fund rather than the Capital Outlay Fund due to the downturn in the economy and is still being allocated to the General Fund.

Operating Revenues and Expenses

Operating revenues and expenses for proprietary funds are those that result from providing services and producing and delivering goods and/or services. It also includes all revenue and expenses not related to capital and related financing, noncapital financing, or investing activities.

Expenditures/Expenses

In the government-wide financial statements, expenses are classified by function for both governmental and business-type activities:

In the fund financial statements, expenditures are classified as follows:

Governmental Funds - By Character	Current (further classified by function)
	Debt Service
	Capital Outlay

Proprietary Fund - By Operating and Nonoperating

In the fund financial statements, governmental funds report expenditures of financial resources. Proprietary funds report expenses relating to use of economic resources.

Interfund Transfers

Permanent reallocation of resources between funds of the reporting entity are classified as interfund transfers. For the purposes of the Statement of Activities, all interfund transfers between individual governmental funds have been eliminated.

NOTE 2 STEWARDSHIP, COMPLIANCE, AND ACCOUNTABILITY

By its nature as a local government unit, the City and its component units are subject to various federal, state, and local laws and contractual regulations. An analysis of the City of Pryor Creek's compliance with significant laws and regulations and demonstration of its stewardship over City resources follows.

FUND ACCOUNTING REQUIREMENTS

The City complies with all state and local laws and regulations requiring the use of separate funds. The legally required funds used by the City include the following:

<i>Fund</i>	<i>Required By</i>
Cemetery Care Fund	State Law
Municipal Utility Department	City Charter
Street and Drainage	State Law
Public Works Authority	Trust Indenture

2.B. DEPOSITS AND INVESTMENTS LAWS AND REGULATIONS

In accordance with state law, all uninsured deposits of municipal funds in financial institutions must be secured with acceptable collateral valued at the lower of market or par. Acceptable collateral includes certain U. S. Government or Government Agency securities, certain State of Oklahoma or political subdivision debt obligations, or surety bonds. As required by 12 U.S.C.A. Section 1823 (e), all financial institutions pledging collateral to the City must have a written collateral agreement approved by the board of directors or loan committee.

2.C. REVENUE RESTRICTIONS

The City has various restrictions placed over certain revenue sources from state or local requirements. The primary restricted revenue sources include:

Revenue Source	Legal Restrictions of Use
Sales Tax	See Notes 1.E. and 3.J.
Gasoline Excise & Commercial Vehicle Tax	Street and Alley Purposes
E-911 revenue	E-911 Emergency Services Purposes
Water, Sewer, Electrical, and Gas Revenue	Debt Service & Utility Operations
Cemetery Revenue (15%)	Cemetery Capital Improvements
Hotel/Motel Tax	Convention and Tourism
Golf Revenue	Golf Operations and Maintenance
Recreation Center Revenues	Recreation Center Operations and Maintenance

For the year ended June 30, 2024, the City complied, in all material respects, with these revenue restrictions.

2.D. DEBT RESTRICTIONS AND COVENANTS

General Obligation Debt

Article 10, Sections 26 and 27, for the Oklahoma Constitution limits the amount of outstanding general obligation bonded debt of the municipality for nonutility or non-street purposes to no more than 10 percent of net assessed valuation. For the year ended June 30, 2024, the City complied with this provision.

Other Long-term Debt

Except as noted in the preceding paragraph, as required by the Oklahoma State Constitution, the City (excluding Public Trusts) may not incur any indebtedness that would require payment from resources beyond the current fiscal year revenue without first obtaining voter approval. For the year ended June 30, 2024, the City incurred no such indebtedness.

2.E. FUND EQUITY RESTRICTIONS

Deficit Prohibition

Title 11, Section 17-211, of the Oklahoma Statutes prohibits the creation of a deficit fund balance in any individual fund. The City of Pryor Creek complied with this statute in all material respects for the year ended June 30, 2024.

NOTE 3. DETAIL NOTES ON TRANSACTION CLASSES/ACCOUNTS

The following notes present detail information to support the amounts reported in the basic financial statements for its various assets, liabilities, equity, revenues, and expenditures/expenses.

3.A. CASH AND INVESTMENTS

Deposits

The City's policies regarding deposits of cash are discussed in Note 1.E. The table presented below is designed to disclose the level of custody credit risk assumed by the City based upon how its deposits were insured or secured with collateral at June 30, 2024. The categories of credit risk are defined as follows:

Category 1 - Insured by FDIC or collateralized with securities held by the City (or public trust) or by its agent in its name

Category 2 - Uninsured but collateralized with securities held by the pledging financial institution's trust department or agent in the City's name.

Category 3 - Uninsured and uncollateralized; or collateralized with securities held by the pledging financial institution, or by its trust department or agent but not in the City's name; or collateralized with no written or approved collateral agreement

<u>Type of Deposits</u>	<u>Total Bank Balance</u>	<u>Credit Risk Category</u>			<u>Total Carrying Value</u>
		<u>1</u>	<u>2</u>	<u>3</u>	
Total Deposits	<u>\$21,382,431</u>	<u>\$ 1,924,378</u>	<u>\$19,458,053</u>	<u>\$ --</u>	<u>\$21,382,431</u>
Reconciliation to Government-wide Statement of Net position:					
Unrestricted cash					\$ 8,665,396
Restricted cash, including time deposits					<u>12,717,035</u>
					<u>\$21,382,431</u>

3.B. RESTRICTED ASSETS

Restricted assets consist of cash, certificates of deposit, investments, and taxes receivable reserved as follows:

Municipal Utility Department

Customer meter deposits - reflected as a long-term liability on the balance sheet	\$ 1,114,130
Reserve for property, plant and equipment replacements and emergency and disaster relief - reflected as a reservation of retained earnings on the balance sheet	3,000,708
Sales tax allocated for capital improvements	6,037,335
Reserved for charter required legal obligations	<u>2,003,390</u>
	<u>\$12,155,563</u>

City of Pryor

Reserve fund for payment of principal and interest on bonds	1,007,628
Construction funds	<u> --</u>
	<u>1,007,628</u>
Grand total	<u>\$13,163,191</u>

Encumbrances are recognized as a reserve on the Municipal Utility Department, a proprietary type fund due to the City Charter's definition and allocation of such fund's computation and distribution of surplus revenues between the General Fund and the reserves of the Municipal Utility Department. See Note 3.J. for additional information.

3.C. ACCOUNTS RECEIVABLE

Accounts receivable of the business-type activities consist of utilities receivable. Accounts receivable of the governmental activities consist of grants receivable.

Accounts receivable of the Municipal Utility Department are reported at their gross value without an allowance for doubtful accounts. All accounts have utility deposits with the Department which can be applied to any unpaid balances. Management feels that such deposits will cover most accounts that might become uncollectible. Accordingly, no allowance for uncollectible accounts has been established. The following is a summary of the bad debts for the current and prior four fiscal years:

June 30, 2024	\$27,942
June 30, 2023	\$29,264
June 30, 2022	\$25,822
June 30, 2021	\$21,429
June 30, 2020	\$29,857

3.D. CAPITAL ASSETS

Capital asset activity for the year ended June 30, 2024, was as follows:

	<i>Balance at July 1, 2023</i>	<i>Additions</i>	<i>Transfers</i>	<i>Disposals</i>	<i>Balance at June 30, 2024</i>
Governmental activities:					
Land	\$ 3,254,997	\$ 18,455	\$ --	\$ --	\$ 3,273,452
Buildings	21,583,877	29,489	61,600	--	21,674,966
Machinery and equipment	12,123,604	1,418,961	--	(42,107)	13,500,458
Infrastructure					
Improvements	53,093,834	591,230	--	--	53,685,064
Land, easements, etc.	7,045,000	--	--	--	7,045,000
Work in progress	<u>211,825</u>	<u>1,029,832</u>	<u>(211,825)</u>	<u>--</u>	<u>1,029,832</u>
Totals at historical cost	<u>97,313,137</u>	<u>3,087,967</u>	<u>(150,225)</u>	<u>(42,107)</u>	<u>100,208,772</u>
Less accumulated depreciation					
Buildings	(3,529,445)	(515,028)	--	--	(4,044,473)
Machinery and equipment	(8,016,339)	(894,981)	--	42,107	(8,869,213)
Infrastructure	<u>(30,305,630)</u>	<u>(1,033,824)</u>	<u>--</u>	<u>--</u>	<u>(31,339,454)</u>
Total accumulated depreciation	<u>(41,851,414)</u>	<u>(2,443,833)</u>	<u>--</u>	<u>42,107</u>	<u>(44,253,140)</u>
Governmental activities capital assets, net	<u>\$ 55,461,723</u>	<u>\$ 644,134</u>	<u>\$ (150,225)</u>	<u>\$ --</u>	<u>\$ 55,955,632</u>
Business-type activities:					
Land and easements	354,810	2,500	--	--	357,310
Buildings	8,351,785	723,410	22,169	--	9,097,364
Machinery and equipment	5,808,273	537,107	--	(59,108)	6,286,272
Utility property	44,821,923	1,099,632	--	(280,009)	45,641,546
Work in progress	<u>22,169</u>	<u>498,810</u>	<u>(22,169)</u>	<u>--</u>	<u>498,810</u>
Total at historical cost	<u>59,358,960</u>	<u>2,861,459</u>	<u>--</u>	<u>(339,117)</u>	<u>61,881,302</u>

	<i>Balance at July 1, 2023</i>	<i>Additions</i>	<i>Transfers</i>	<i>Disposals</i>	<i>Balance at June 30, 2024</i>
Less accumulated depreciation:					
Buildings	(3,659,108)	(233,472)	--	--	(3,892,580)
Machinery and equipment	(3,332,340)	(325,649)	--	59,107	(3,598,882)
Utility property	<u>(18,195,057)</u>	<u>(1,007,687)</u>	<u>--</u>	<u>262,440</u>	<u>(18,940,304)</u>
Total accumulated depreciation	<u>(25,186,505)</u>	<u>(1,566,808)</u>	<u>--</u>	<u>321,547</u>	<u>(26,431,766)</u>
Business-type capital assets, net	<u>\$ 34,172,455</u>	<u>\$ 1,294,651</u>	<u>\$ --</u>	<u>\$ (17,570)</u>	<u>\$ 35,449,536</u>

* Depreciation expense was charged to governmental activities as follows:

General government:		
City Clerk		\$ 8,620
General government		<u>139,318</u>
Total General Government		<u>147,938</u>
Public safety and judiciary:		
Police		521,421
Fire		373,408
Civil emergency management		<u>233</u>
Total public safety and judiciary		<u>895,062</u>
Transportation:		
Streets		<u>1,159,421</u>
Total transportation		<u>1,159,421</u>
Cultural, parks and recreation:		
Library		103,303
Cemetery		29,962
Swimming pool and parks		<u>108,147</u>
Total cultural, parks and recreation		<u>241,412</u>
Total depreciation expense		<u>\$ 2,443,833</u>

3.E. INVENTORY

Inventory consists of utility materials and supplies that will be expensed when used for repairs and/or capitalized when used for improvements. The Department maintains such inventories for ordinary and emergency repairs and improvements and many of the items are in the nature of a back-up to parts of the utility system. Thus, many of the inventory items will not be used in the next fiscal year. Accordingly, inventory has not been classified as a current asset.

Inventory is stated at cost on a first-in, first-out basis.

3.F. ACCOUNTS PAYABLE

Payables in all funds are composed of payables to vendors only. Accrued expenses consist mainly of accrued payroll.

3.G. LONG-TERM DEBT

The reporting entity's long-term debt is segregated between the amounts to be repaid from governmental activities and amounts to be repaid from business-type activities.

Governmental Activities

The following is a summary of the City's (excluding Proprietary Funds) long-term debt transactions for the year ended June 30, 2024:

Debt outstanding, July 1, 2023	\$ 12,351,013
Additions	28,920
Retirements	<u>(1,055,211)</u>
Debt outstanding, June 30, 2024	<u>\$ 11,324,722</u>

The provisions of such debt at June 30, 2024 are as follows:

	<u>Total Debt</u>	<u>Due Within One Year</u>
Lease/purchase of computer equipment payable in monthly installments of \$3,930.39, including 1.98% interest until November, 2032	323,735	41,127
Lease/purchase of police dispatch system improvements payable in monthly installments of \$2,000.62, including 1.98% interest until December, 2030	145,024	21,329
2019 sales tax revenue note in the original amount of \$10,000,000, payable in varying amounts of principal and interest at 2.25% until January 1, 2035. Secured by a .75 cent sales tax	7,955,000	620,000
2023 sales tax revenue note in the original amount of \$3,130,000, payable in varying amounts of principal and interest at 2.339% until January 1, 2035.	2,725,000	230,000
Lease/purchase of police cars, payable in monthly Installments of \$6,466.19, including 1.75% interest Until May, 2026	142,480	140,679
Lease/purchase of various office furniture payable in monthly installments of \$649.53, including 1.98% interest until April, 2032	<u>33,483</u>	<u>33,483</u>

Total	11,324,722	<u>\$ 1,086,618</u>
Amount due in one year	<u>1,086,618</u>	
Long term portion	<u>\$ 10,238,104</u>	

The following is a summary of payments due until maturity:

	<u>Principal</u>
Year ending June 30, 2025	1,086,618
Year ending June 30, 2026	940,712
Year ending June 30, 2027	965,385
Year ending June 30, 2028	991,619
Year ending June 30, 2029	1,017,876
Five years ending June 30, 2034	5,322,512
Four years ending June 30, 2039	1,000,000

The following is a summary of the City's Golf Course Fund's long-term debt transactions for the year ended June 30, 2024:

Debt outstanding, July 1, 2023	\$ 48,902
Additions	--
Retirements	<u>(29,150)</u>
	<u>\$ 19,752</u>

The provisions of such debt at June 30, 2024 are as follows:

	<u>Total Debt</u>	<u>Due Within One Year</u>
Lease/purchase of golf carts for the Pryor Creek Golf Course in March, 2023, payable in monthly installments of \$2,487.01 at 1.95% interest until March, 2025	<u>\$ 19,752</u>	<u>\$ 19,752</u>
Total	\$ 19,752	19,752
Amount due in one year	<u>19,752</u>	
Long-term portion	<u>\$ --</u>	

The following is a summary of payments due until maturity:

Year ending June 30, 2025	19,752
---------------------------	--------

The following is a summary of the Municipal Utility Board's long-term debt transactions for the year ending June 30, 2024:

Debt outstanding, July 1, 2023	\$ 1,000,000
Additions	--
Retirements	<u>(118,988)</u>
Debt outstanding, June 30, 2024	<u>\$ 881,012</u>

The provisions of such debt at June 30, 2024 are as follows:

	<u>Total Debt</u>	<u>Due Within One Year</u>
Financed excess electric billing costs As a result of a natural disaster winter Storm in 2020. Payments will be \$11,518, Including 2% interest until October 2032	<u>\$ 881,012</u>	<u>\$ 121,475</u>
Total	\$ 881,012	<u>\$ 121,475</u>
Amount due in one year	<u>121,475</u>	
Long Term portion	<u>\$ 759,537</u>	

The following is a summary of payments due until maturity:

Year ending June 30, 2025	\$121,475
Year ending June 30, 2026	123,961
Year ending June 30, 2027	126,498
Year ending June 30, 2028	129,063
Year ending June 30, 2029	131,729
Three years ending June 30, 2032	248,286

Non-Commitment Debt

The notes and bonds payable comprising the Pryor Creek Economic Development Authority's indebtedness are not indebtedness of the State of Oklahoma, nor of the City of Pryor Creek, nor are they personal obligations of the Pryor Creek Economic Development Authority but are obligations of the Authority payable solely from the Trust Estate consisting of the Authority notes and related Financing Agreements and other security outlined in the Mortgage or Bond indentures.

This debt is considered non-commitment debt to the City and Authority since the debt payments are made solely from the notes receivable or financing agreement proceeds from industrial occupants. Payments are made directly by the industrial occupants to trustee banks who pay the bondholders. In the event of default by the industrial occupants, the City or Authority has no obligation, in substance, to make any payments on the debt since the notes receivable, financing agreements and mortgages on the property with the industrial occupant are the only security for the debt.

As a result of the non-commitment determination, the Authority's indebtedness and related receivables from industrial occupants are not recorded in the financial statements.

3.H ACCRUED COMPENSATED ABSENCES

City employees are entitled to certain compensated absences based on their length of employment. This liability is reflected in the balance sheet of the proprietary funds. Additionally, the full amount of the accrual is included in the Street and Drainage Special Revenue Fund, as that fund appears to have sufficient expendable available financial resources to liquidate the obligation.

The accrued compensated absences for the Governmental Funds totals \$201,081. Consistent with prior years, only \$46,815 of this amount has been included as a liability in the General Fund in the Fund financial statements. However, the \$201,081 is reflected as a liability on the government-wide statements.

3.I. DUE TO/FROM OTHER FUNDS - OPERATING AND CAPITAL TRANSFERS

As of June 30, 2024, interfund receivables and payables which resulted from various interfund transactions were as follows:

	<i>Due From Other Funds</i>	<i>Due to Other Funds</i>
General Fund	\$ 337,565	\$ 2,198
Covid Relief Fund	--	337,565
Public Works Authority	3,711	--
Municipal Utility Department	<u>2,198</u>	<u>3,711</u>
	<u>\$ 343,474</u>	<u>\$ 343,474</u>

A summary of the major operating transfers during the year consisted of the following:

	<u>From</u>		<u>To</u>	
	<u>Fund</u>	<u>Amount</u>	<u>Fund</u>	<u>Amount</u>
Distribution of current operating income	Municipal Utility Department	\$775,200	General Fund	\$775,200
Funds for Economic Development Trust Authority	Main Street Fund	250,000	EDTA	250,000
Transfer of funds For police department Operations	Capital Improvements Fund	256,924	General Fund	256,924

3.J. EQUITY

Reserve for Charter Required Legal Obligations - It has been interpreted by legal counsel that the Department is to encumber cash for goods and services ordered but not received as of the end of the year for purposes of determining "surplus revenues" that can be added to reserves or remitted to the City of Pryor Creek. Accordingly, a reserve has been provided for such encumbrances.

Reserved for Capital Improvements from Sales Tax - This reserve is funded by a 1/2 cent sales tax and interest revenue. The Department is utilizing such revenues to fund depreciation for the waste water treatment plant as required in grant agreements. The excess can only be used for utility systems improvements and additions. The activity in this reserve account is summarized as follows:

Balance - July 1, 2023	<u>\$ 7,481,824</u>
Additions	
Reserve transfers in from sales tax	1,354,515
Interest income applicable to reserve balance	<u>303,127</u>
	<u>1,657,642</u>
Subtractions	
Equipment and system additions paid for from reserves	<u>3,102,131</u>
	<u>3,102,131</u>
Balance - June 30, 2024	<u>\$ 6,037,335</u>

Reserve for Property, Plant and Equipment and Emergency and Disaster Relief - This reserve is authorized in the Charter of the City of Pryor Creek and is in accordance with State Statutes. It provides a method of funding future replacements and additions to fixed assets and a reserve for disasters.

The activity in this reserve account is summarized as follows:

Balance - July 1, 2023	\$ 3,121,063
Subtractions	
Contribution of general operations to increase unreserved cash to level of liabilities as of June 30, 2024	120,355
Balance June 30, 2024	\$ 3,000,708

NOTE 4. OTHER NOTES

4.A. EMPLOYEE PENSION AND OTHER BENEFIT PLANS

The City participates in four employee pension systems as follows:

Name of Plan /System	Type of Plan
Oklahoma Police Pension and Retirement Fund	Cost Sharing Multiple Employer-Defined Benefit Plan
Oklahoma Firefighters Pension and Retirement Fund	Cost Sharing Multiple Employer - Defined Benefit Plan
Oklahoma Municipal Retirement Fund (OkMRF)	Agent Multiple Employer - Defined Contribution Plan
Oklahoma Municipal Retirement Fund (OkMRF)	Agent Multiple Employer - Defined Contribution Plan

Oklahoma Police Pension and Retirement System

Plan description - The City of Pryor Creek, as the employer, participates in the Oklahoma Police Pension and Retirement Plan, a cost-sharing multiple employer defined benefit pension plan administered by the Oklahoma Police Pension and Retirement System (OPPRS). Title 11 of the Oklahoma State Statutes, through the Oklahoma Legislature, grants the authority to establish and amend the benefit terms to the OPPRS. OPPRS issues a publicly available financial report that can be obtained at the Plan's administrative web site.

Benefits provided - OPPRS provides retirement, disability and death benefits to members of the plan. The normal retirement date under the Plan is the date upon which the participant completes 20 years of credited services, regardless of age. Participants become vested upon completing 10 years of credited service. As a contributing participant of the Plan, no vesting occurs prior to completing 10 years of credited service. Participants' contributions are refundable, without interest, upon termination prior to normal retirement. Participants who have completed 10 years of credited service may elect a vested benefit in lieu of having their accumulated contributions refunded. If the vested benefit is elected, the participant is entitled to a monthly retirement benefit commencing on the date the participant reaches 50 years of age or the date the participant would have had 20 years of credited service had employment continued uninterrupted, whichever is later.

Monthly retirement benefits are calculated at 2.5% of the final average salary (defined as the average paid base salary of the officer over the highest 30 consecutive months of the last 60 months of credited service) multiplied by the years of credited service, with a maximum of 30 years of credited service considered.

Monthly benefits for participants due to permanent disability incurred in the line of duty are 2.5% of the participant's final average salary multiplied by 20 years. This disability benefit is reduced by stated percentages for partial disability based on the percentage of impairment. After 10 years of credited service, participants who retire due to disability incurred from any cause are eligible for a monthly benefit based on 2.5% of their final average salary multiplied by the years of service. This disability benefit is also reduced by stated percentages for partial disability based on the percentage of impairment. Effective, July 1, 1998, once a disability benefit is granted to a participant, that participant is no longer allowed to apply for an increase in the dollar amount of the benefit at a subsequent date.

Survivor's benefits are payable in full to the participant's beneficiary upon the death of a retired participant. The beneficiary of any active participant killed in the line of duty is entitled to a pension benefit.

Contributions - The contribution requirements of the Plan are at an established rate determined by Oklahoma Statute and are not based on actuarial calculations. Employees are required to contribute 8% of their annual pay. Participating cities are required to contribute 13% of the employees' annual pay. Contributions to the pension plan from the City were \$257,975.

Pension Liabilities, Pension Expense and Deferred Outflows of Resources and Deferred Inflows of Resources Related to Pensions

At June 30, 2024, the City reported deferred outflows of resources and deferred inflows of resources related to pensions from the following sources:

	<u>Deferred Outflows of Resources</u>	<u>Deferred Inflows of Resources</u>
Differences between expected and actual earnings	\$ 407,658	\$ 22,966
Changes of assumptions	--	277,967
Net difference between projected and actual earnings on pension plan investments	1,863,883	1,126,065
Changes in proportion and differences between City contributions and proportionate share of contributions	--	--
City contributions subsequent to the measurement date	<u>257,975</u>	<u>--</u>
Total	<u>\$2,529,516</u>	<u>\$1,426,998</u>

\$257,975 reported as deferred outflows of resources related to pensions resulting from City contributions subsequent to the measurement date will be recognized as an increase of the net pension asset in the year ended June 30, 2024. Any other amounts reported as deferred outflows of resources and deferred inflows of resources related to pension will be recognized in pension expense as follows:

Year ended June 30	
2024	\$ 138,498
2025	2,367
2026	574,952
2027	130,771
2028	<u>(2,045)</u>
	<u>\$ 844,543</u>

Actuarial Assumptions - The total pension liability was determined by an actuarial valuation as of July 1, 2023, using the following actuarial assumptions applied to all prior periods included in the measurement:

Inflation	2.75%
Salary increases	3.5% to 12% average, including inflation
Investment rate of return	7.5% net of pension plan investment expense
Mortality rates:	<p>Active employees (pre-retirement) RP-2000 Blue Collar Healthy Combined Table with age set back 4 years with fully generational improvement using Scale AA.</p> <p>Active employees (post-retirement) and non-disabled pensioners: RP-2000 Blue Collar Healthy Combined table with fully generational improvement using scale AA.</p> <p>Disabled pensioners: RP-2000 Blue Collar Healthy Combined Table with age set forward 4 years with fully generational improvement using scale AA.</p>

The actuarial assumptions used in the July 1, 2023 valuation were based on the results of an actuarial experience study for the period July 1, 2007 to June 30, 2012.

The long-term expected rate of return on pension plan investments was determined using a building block method in which best-estimate ranges of expected future real rates of return (expected returns, net of pension plan investment expense and inflation) are developed for each major asset class. These ranges are combined to produce the long-term expected rate of return by weighing the expected future real rates of return by the target asset allocation percentage and by adding expected inflation. Best estimates of arithmetic real rates of return for each major asset class included in the pension plan's target asset allocation as of June 30, 2023 are summarized in the following table:

<u>Asset Class:</u>	<u>Long-term Expected Real Rate of Return</u>
Fixed income	3.22%
Domestic equity	4.55%
International equity	8.50%
Real estate	7.97%
Private equity	9.36%

The current allocation policy is that approximately 65% of assets in equity instruments, including public equity, long-short hedge, venture capital and private equity strategies; approximately 20% of assets in fixed income to include investment grade bonds, high yield and non-dollar denominated bonds, convertible bonds and low volatility hedge fund strategies; and 15% of assets in real assets to include real estate, commodities and other strategies.

Discount Rate - The discount rate used to measure the total pension liability was 7.5%. The projection of cash flows used to determine the discount rate assumed that contributions from plan members will be made at the current contribution rate and that contributions from employers will be made at contractually required rates determined by State statutes. Projected cash flows also assume the State of Oklahoma will continue contributing 14% of the insurance premium as established by statute. Based on these assumptions, the pension plan's fiduciary net position was projected to be available to make all projected future benefit payments of current plan members. Therefore, the long-term expected rate of return on pension plan investments was applied to all periods of projected benefit payments to determine the total pension liability.

Sensitivity of the Net Pension Liability to Changes in the Discount Rate -The following presents the net pension liability of the employers calculated using the discount rate of 7.5%, as well as what the Plan's net pension liability would be if it were calculated using a discount rate that is 1 percentage point lower (6.5%) or 1 percentage higher (8.5%) than the current rate.

	1% Decrease <u>(6.5%)</u>	Current Discount Rate <u>(7.5%)</u>	1% Increase <u>(8.5%)</u>
Employer's net pension liability (asset)	\$ 1,406,013	\$(148,916)	\$(1,465,452)

Pension plan fiduciary net position - Detailed information about the pension plan's fiduciary net position is available in the separately issued financial report of the OPPR, which can be located on the Plan Administrative web site.

Oklahoma Firefighter's Pension and Retirement System

Plan description - The City of Pryor Creek, as the employer, participates in the Firefighters Pension and Retirement, a cost-sharing multiple-employer defined benefit pension plan administered by the Oklahoma Firefighters Pension and Retirement System (FPRS). Title 11 of the Oklahoma State Statutes grants the authority to establish and amend the benefit terms to the FPRS. FPRS issues a publicly available financial report that can be obtained at the Plan's administrative web site.

Benefits provided - FPRS provides retirement, disability and death benefits to members of the plan. Benefits for members hired prior to November 1, 2013 are determined as 2.5 percent of the employee's final average compensation times the employee's years of service and have reached the age of 50 or have completed 20 years of service, whichever is later. For volunteer firefighters, the monthly pension benefit for normal retirement is \$150.60 per month. Benefits vest with 10 years or more of service.

Benefits for members hired after November 1, 2013 are determined as 2.5 percent of the employee's final average compensation times the employee's years of service and have reached the age of 50 or have completed 22 years of service, whichever is later. For volunteer firefighters, the monthly pension benefit for normal retirement is \$165.66 per month. Benefits vest with 11 years or more of service.

All firefighters are eligible for immediate disability benefits. For paid firefighters, the disability in-the-line-of duty benefit for firefighters with less than 20 years of service is equal to 50% of final average monthly compensation, based on the most recent 30 months of service. For firefighters with over 20 years of service a disability in-the-line-of-duty is calculated based on 2.5% of final average monthly compensation, based on the most recent 30 months, per year of service, with a maximum of 30 years of service. For disabilities not in-the-line-of-duty, the benefit is limited to only those with less than 20 years of service and is 50% of final average monthly compensation based on the most recent 60-month salary as opposed to 30 months. For volunteer firefighters, the not-in-the-line-of-duty disability is also limited to only those with less than 20 years of service and is \$7.53 per year of service. For volunteer firefighters, the in-the-line-of-duty pension is \$150.60 with less than 20 years of service or \$7.53 per year of service with a maximum of 30 years.

A \$5,000 lump sum death benefit is payable to the qualified spouse or designated recipient upon the participant's death. The \$5,000 death benefit does not apply to members electing the vested benefit.

Contributions - The contributions requirements of the Plan are at an established rate determined by Oklahoma Statute and are not based on actuarial calculations. Employees are required to contribute 9% of their annual pay. Participating cities are required to contribute 14% of the employees' annual pay. Contributions to the pension plan from the City were \$138,613.

Pension Liabilities, Pension Expense and Deferred Outflows of Resources and Deferred Inflows of Resources Related to Pensions - At June 30, 2024, the City reported a net pension liability of \$3,987,322 for its proportionate share of the net pension liability. The net pension liability was measured as of June 30, 2023 and the total pension liability used to calculate the net pension liability was determined by an actuarial valuation as of July 1, 2023. The City's proportion of the net pension asset was based on the City's contributions received by the pension plan relative to the total contributions received by pension plan for all participating employers as of June 30, 2023. Based upon this information, the City's proportion was .309035%.

\$173,609 reported as deferred outflows of resources related to pensions resulting from City contributions subsequent to the measurement date will be recognized as a reduction of the net pension liability in the year ended June 30, 2024. Any other amounts reported as deferred outflows of resources and deferred inflows of resources related to pension will be recognized in pension expense as follows:

	<u>Deferred Outflows of Resources</u>	<u>Deferred Inflows of Resources</u>
Differences between expected and actual earnings	\$ 474,203	\$ 5,062
Changes of assumptions	--	6,393
Net difference between projected and actual earnings on pension plan investments	1,301,981	1,038,942
City contributions subsequent to the measurement date	<u>173,609</u>	<u>--</u>
Total	<u>\$1,949,793</u>	<u>\$1,050,397</u>
Year ended June 30		
2024	\$ 220,983	
2025	74,231	
2026	444,010	
2027	<u>(13,437)</u>	
	<u>\$ 725,787</u>	

Actuarial Assumptions - The total pension liability was determined by an actuarial valuation as of July 1, 2023, using the following actuarial assumptions, applied to all prior periods included in the measurement:

Inflation:	2.75%
Salary increases:	2.75% to 10.5% average, including inflation
Investment rate of return:	7.5% net of pension plan investment expense

Mortality rates were based on the RP2000 combined healthy with blue collar adjustment as appropriate, with adjustments for generational mortality improvement using scale AA for health lives and no mortality improvement for disabled lives.

The actuarial assumptions used in the July 1, 2023 valuation were based on the results of an actuarial experience study for the period July 1, 2007 to June 30, 2012.

The long-term expected rate of return on pension plan investments was determined using a building block method in which best estimate ranges of expected future real rates of return (expected returns, net of pension plan investment expense and inflation) are developed for each major asset class. These ranges are combined to produce the long-term expected rate of return by weighing the expected future real rates of return by the target asset allocation percentage and by adding expected inflation. Best estimates of arithmetic real rates of return for each major asset class included in the pension plan's target asset allocation as of June 30, 2023, are summarized in the following table:

	<u>Long-term Expected Real Rate of Return</u>
Domestic equity	5.73%
International equity	8.50%
Fixed income	3.53%
Real estate	7.97%
Other assets	9.73%

Discount Rate: The discount rate used to measure the total pension liability was 7.5%. The projection of cash flows used to determine the discount rate assumed that contributions from plan members will be made at the current contribution rate and that contributions from employers will be made at contractually required rates, determined by State statutes. Projected cash flows also assume the State of Oklahoma will continue contributing 36% of the insurance premium, as established by statute. Based on these assumptions, the pension plan's fiduciary net position was projected to be available to make all projected future benefit payments of current plan members. Therefore, the long-term expected rate of return on pension plan investments was applied to all periods of projected benefit payments to determine the total pension liability.

Sensitivity of the Net Pension Liability to Changes in the Discount Rate -The following presents the net pension liability of the employers calculated using the discount rate of 7.5%, as well as what the Plan's net pension liability would be if it were calculated using a discount rate that is 1 percentage point lower (6.5%) or 1 percentage point higher (8.5%) than the current rate:

	1% Decrease <u>(6.5%)</u>	Current Discount Rate <u>(7.5%)</u>	1% Increase <u>(8.5%)</u>
Employer's net pension liability (asset)	\$5,195,653	\$3,987,322	\$2,976,838

Pension plan fiduciary net position - Detailed information about the pension plan's fiduciary net position is available in the separately issued financial report of the FPRS, which can be located on the Plan Administrative web site.

III *Pryor Creek Public Employee Retirement System (PCPERS)*

A. Plan Description

The City of Pryor Creek contributes to the Pryor Creek Public Employee Retirement System (PCPERS), which is a defined contribution pension plan administered by an insurance company. The PCPERS covers all employees of the City of Pryor Creek who are not covered by the Oklahoma Firefighters Pension and Retirement System, the Oklahoma Police Pension and Retirement System, or the employees of the Municipal Utility Department, which has a separate plan.

A defined contribution pension plan provides pension benefits in return for services rendered, provides an individual account for each participant, and specifies how contributions to the individual's account are to be determined instead of specifying the amount of benefits the individual is to receive. Under a defined contribution pension plan, the benefits a participant will receive depend solely on the amount contributed to the participant's account, the returns earned on investments of those contributions, and forfeitures of other participants' benefits that may be allocated to such participant's account. Coverage is extended to eligible employees who have completed 6 months of service and attained the age of 20.5. Contributions made by an employee vest immediately and contributions made by the City vest 10% for each year of service beginning with the first year.

B. Contributions Required and Made

Employees' contributions to the plan are voluntary. An employee can, however, make elective contributions to the plan so that his or her contributions can be 10% of gross earnings. The City's required contribution to the plan is 9% of the employee's gross earnings during the current year.

During the fiscal year ending June 30, 2024, the City's required and actual contributions amounted to \$207,511, with a current year covered payroll of \$2,469,246.

C. Related Party Investments

The PCPERS held no securities of the City or other related parties during the year or as of the close of the fiscal year.

IV. *Municipal Utility Department of Pryor, Oklahoma Money Purchase Plan*

A. Plan Description

The Municipal Utility Board contributes to the Municipal Utility Department of Pryor, Oklahoma Money Purchase Plan, (MUDPOMPP) which is a defined contribution pension plan administered by an insurance company. The MUDPOMPP covers all employees of the Department.

A defined contribution pension plan provides pension benefits in return for services rendered, provides an individual account for each participant, and specifies how contributions to the individual's account are to be determined instead of specifying the amount of benefits the individual is to receive. Under a defined contribution pension plan, the benefits a participant will receive depend solely on the amount contributed to the participant's account, the returns earned on investments of those contributions, and forfeitures of other participants' benefits that may be allocated to such participant's account. Coverage is extended to eligible employees who have completed one year of service and attained the age of 21. Contributions are not made by an employee and contributions made by the Department are vested 20% in the plan after two years of service. After six years, employees are fully vested.

Contributions Required and Made

Employee contributions to the plan are not allowed. The Department's required contribution to the plan was 12% for the year.

During the fiscal year ending June 30, 2024, the Department's required and actual contributions amounted to \$368,500, with a current year covered payroll of \$3,070,837.

B. Related Party Investments

The MUDPOMPP held no securities of the City or other related parties during the year or as of the close of the fiscal year.

4.B. Adoption of ASC 842 and Lease Obligations

During the current year, the City adopted Accounting Standards Update (ASU) No. 2016-02. Leases (Topic 842), which replaces the existing guidance in ASC 840, Leases. ASC 842 requires lessees to recognize a right-of-use (ROU) asset and lease liability on the balance sheet for most leases, including operating leases.

The City elected to apply ASC 842 using the modified retrospective approach, which allows for the application of the standard at the beginning of the earliest period presented in the financial statements. In accordance with ASC 842-10-65-1 (f), the City elected to apply the package of practical expedients, which permits the City to not reassess (1) whether any expired or existing contracts are or contain leases, (2) the lease classification for any expired or existing leases, and (3) initial direct costs for any existing leases.

As a result of applying the modified retrospective approach and the package of practical expedients, the impact of the new standard on the financial statements is immaterial. Therefore, no adjustments to the financial statements have been recorded for the adoption of ASC 842. The City will continue to assess its lease arrangements and the potential impact of ASC 842 on its financial statements and will apply the new standard to future lease transactions, as appropriate.

4.C. Risk Management

The City is exposed to various risks of loss related to torts, theft of, damage to, or destruction of assets; errors and omissions; injuries to employees; and natural disasters. The City manages these various risks through the purchase of commercial insurance with varying deductibles. These deductibles are well below materiality levels for the City. Additionally, the Municipal Utility Department has reserves for replacement of assets as described in Note 3.J. During the last three years no claim has been settled for amounts in excess of insurance coverage.

4.D. Subsequent Events

There were no other subsequent events to disclose as of February 24, 2026.

4.E. Commitments and Contingencies

As of June 30, 2024, the City had the following pending litigation claims:

City of Pryor v. MUB. CV-2024-6. This action seeks injunctive relief to determine the legal relationship between the City of Pryor Creek and Pryor Creek Municipal Utilities Board. The matter was still pending as of June 30, 2024 and as of the reporting date of February 24, 2026.

REQUIRED SUPPLEMENTARY INFORMATION

Required supplementary information includes financial information and disclosures that are required by the GASB, but are not considered a part of the basic financial statements. Such information includes:

Defined Benefit Cost Sharing Plans:

Police:

Schedule of the City's Proportionate Share of the Net Pension Liability
(Asset)
Schedule of City Contributions

Fire:

Schedule of the City's Proportionate Share of the Net Pension Liability
(Asset)
Schedule of City Contributions

Budgetary Comparison Schedules - General Fund

**CITY OF PRYOR CREEK, OKLAHOMA
REQUIRED SUPPLEMENTARY INFORMATION
ON PENSION PLAN FUNDING PROGRESS
FOR THE YEAR ENDED 6/30/2024**

**Schedule of the City of Pryor's Proportionate Share
of the Net Pension Liability (Asset)
Oklahoma Police Pension and Retirement System
Last 10 Fiscal Years***

	<u>2015</u>	<u>2016</u>	<u>2017</u>	<u>2018</u>	<u>2019</u>
City's proportion of the net pension liability (asset)	0.3660%	0.3667%	0.3663%	0.3314%	0.3155%
City's proportionate share of the net pension liability (asset)	\$ (123,243)	\$ 14,994	\$ 551,848	\$ 25,492	\$ (150,292)
City's covered employee payroll	\$ 1,063,308	\$ 1,084,017	\$ 1,054,994	\$ 986,806	\$ 1,205,704
City's proportionate share of the net pension liability (asset) as a percentage of its covered employee payroll	-11.590%	1.380%	52.310%	2.584%	-12.470%
Plan fiduciary net position as a percentage of the total pension liability (asset)	101.530%	99.820%	93.500%	99.680%	101.890%
	<u>2020</u>	<u>2021</u>	<u>2022</u>	<u>2023</u>	<u>2024</u>
City's proportion of the net pension liability (asset)	0.3708%	0.4170%	0.4478%	0.4833%	0.4876%
City's proportionate share of the net pension liability (asset)	\$ (23,670)	\$ 478,873	\$ (2,148,346)	\$ (387,533)	\$ (148,916)
City's covered employee payroll	\$ 1,465,497	\$ 1,585,955	\$ 1,761,233	\$ 2,022,313	\$ 2,096,073
City's proportionate share of the net pension liability (asset) as a percentage of its covered employee payroll	1.620%	30.190%	-121.980%	-19.160%	-7.105%
Plan fiduciary net position as a percentage of the total pension liability (asset)	100.240%	95.800%	117.070%	102.740%	101.020%

* The amounts present for each fiscal year were determined as of 6/30 of the previous year.

**CITY OF PRYOR CREEK, OKLAHOMA
REQUIRED SUPPLEMENTARY INFORMATION
ON PENSION PLAN FUNDING PROGRESS
FOR THE YEAR ENDED 6/30/2024**

**Schedule of the City of Pryor's Contributions
Oklahoma Police Pension and Retirement System
Last 10 Fiscal Years***

	<u>2015</u>	<u>2016</u>	<u>2017</u>	<u>2018</u>	<u>2019</u>
Statutorily required contributions	\$ 135,130	\$ 138,587	\$ 128,478	\$ 125,111	\$ 156,741
Contributions in relation to the statutorily required contribution	<u>\$ 135,130</u>	<u>\$ 138,587</u>	<u>\$ 128,478</u>	<u>\$ 125,111</u>	<u>\$ 156,741</u>
Contribuiton deficiency (excess)	<u>\$ -</u>	<u>\$ -</u>	<u>\$ -</u>	<u>\$ -</u>	<u>\$ -</u>
City's covered employee payroll	<u>\$ 1,063,308</u>	<u>\$ 1,084,017</u>	<u>\$ 1,054,994</u>	<u>\$ 986,806</u>	<u>\$ 1,205,704</u>
Contributions as a percentage of covered employee payroll	13%	13%	13%	13%	13%
	<u>2020</u>	<u>2021</u>	<u>2022</u>	<u>2023</u>	<u>2024</u>
Statutorily required contributions	\$ 181,736	\$ 201,466	\$ 216,873	\$ 255,945	\$ 257,975
Contributions in relation to the statutorily required contribution	<u>\$ 181,736</u>	<u>\$ 201,466</u>	<u>\$ 216,873</u>	<u>\$ 255,945</u>	<u>\$ 257,975</u>
Contribuiton deficiency (excess)	<u>\$ -</u>	<u>\$ -</u>	<u>\$ -</u>	<u>\$ -</u>	<u>\$ -</u>
City's covered employee payroll	<u>\$ 1,397,969</u>	<u>\$ 1,565,956</u>	<u>\$ 1,761,233</u>	<u>\$ 2,022,313</u>	<u>\$ 2,096,073</u>
Contributions as a percentage of covered employee payroll	13%	13%	12%	13%	12%

* The amounts present for each fiscal year were determined as of 6/30 of the previous year.

**CITY OF PRYOR CREEK, OKLAHOMA
REQUIRED SUPPLEMENTARY INFORMATION
ON PENSION PLAN FUNDING PROGRESS
FOR THE YEAR ENDED 6/30/2024**

**Schedule of the City of Pryor's Proportionate Share
of the Net Pension Liability (Asset)
Oklahoma Firefighters Pension and Retirement System
Last 10 Fiscal Years***

	<u>2015</u>	<u>2016</u>	<u>2017</u>	<u>2018</u>	<u>2019</u>
City's proportion of the net pension liability (asset)	0.216400%	0.215800%	0.216400%	0.196970%	0.184386%
City's proportionate share of the net pension liability (asset)	\$ 2,225,501	\$ 2,290,679	\$ 2,601,588	\$ 2,477,344	\$ 2,079,533
City's covered employee payroll	\$ 593,815	\$ 597,498	\$ 576,380	\$ 561,212	\$ 645,477
City's proportionate share of the net pension liability (asset) as a percentage of its covered employee payroll	374.780%	383.400%	451.370%	441.428%	321.550%
Plan fiduciary net position as a percentage of the total pension liability (asset)	68.12%	68.27%	64.87%	66.61%	70.73%
	<u>2020</u>	<u>2021</u>	<u>2022</u>	<u>2023</u>	<u>2024</u>
City's proportion of the net pension liability (asset)	0.211085%	0.240908%	0.278615%	0.301326%	0.309035%
City's proportionate share of the net pension liability (asset)	\$ 2,230,461	\$ 2,967,779	\$ 1,834,868	\$ 3,940,544	\$ 3,987,322
City's covered employee payroll	\$ 771,028	\$ 904,068	\$ 1,013,219	\$ 1,218,921	\$ 1,244,967
City's proportionate share of the net pension liability (asset) as a percentage of its covered employee payroll	289.280%	328.270%	181.090%	323.280%	320.275%
Plan fiduciary net position as a percentage of the total pension liability (asset)	72.85%	69.98%	84.24%	69.49%	70.85%

* The amounts present for each fiscal year were determined as of 6/30 of the previous year.

**CITY OF PRYOR CREEK, OKLAHOMA
REQUIRED SUPPLEMENTARY INFORMATION
ON PENSION PLAN FUNDING PROGRESS
FOR THE YEAR ENDED 6/30/2024**

**Schedule of the City of Pryor's Contributions
Oklahoma Firefighters Pension and Retirement System
Last 10 Fiscal Years***

	<u>2015</u>	<u>2016</u>	<u>2017</u>	<u>2018</u>	<u>2019</u>
Statutorily required contributions	\$ 81,592	\$ 82,511	\$ 77,421	\$ 75,816	\$ 90,367
Contributions in relation to the statutorily required contribution	<u>\$ 81,592</u>	<u>\$ 82,511</u>	<u>\$ 77,421</u>	<u>\$ 75,816</u>	<u>\$ 90,367</u>
Contribuiton deficiency (excess)	<u>\$ -</u>	<u>\$ -</u>	<u>\$ -</u>	<u>\$ -</u>	<u>\$ -</u>
City's covered employee payroll	<u>\$ 593,815</u>	<u>\$ 597,498</u>	<u>\$ 576,380</u>	<u>\$ 561,212</u>	<u>\$ 645,477</u>
Contributions as a percentage of covered employee payroll	13.74%	13.20%	13.43%	13.51%	14.00%
Contributions per volunteer fireman	\$ 60	\$ 60	\$ 60	\$ 60	\$ 60
	<u>2020</u>	<u>2021</u>	<u>2022</u>	<u>2023</u>	<u>2024</u>
Statutorily required contributions	\$ 107,302	\$ 125,754	\$ 138,613	\$ 167,050	\$ 173,609
Contributions in relation to the statutorily required contribution	<u>\$ 107,302</u>	<u>\$ 125,754</u>	<u>\$ 138,613</u>	<u>\$ 167,050</u>	<u>\$ 173,609</u>
Contribuiton deficiency (excess)	<u>\$ -</u>	<u>\$ -</u>	<u>\$ -</u>	<u>\$ -</u>	<u>\$ -</u>
City's covered employee payroll	<u>\$ 771,028</u>	<u>\$ 904,068</u>	<u>\$1,013,219</u>	<u>\$1,218,921</u>	<u>\$1,244,967</u>
Contributions as a percentage of covered employee payroll	13.92%	13.91%	13.68%	13.70%	13.94%
Contributions per volunteer fireman	\$ 60	\$ 60	\$ 60	\$ 60	\$ 60

* The amounts present for each fiscal year were determined as of 6/30 of the previous year.

REQUIRED SUPPLEMENTARY INFORMATION

Required supplementary information includes financial information and disclosures that are required by the GASB, but are not considered a part of the basic financial statements. Such information includes:

Budgetary Comparison Schedules - General Fund

**CITY OF PRYOR CREEK, OKLAHOMA
BUDGETARY COMPARISON SCHEDULE
GENERAL FUND
YEAR ENDED JUNE 30, 2024**

	<u>Budgeted Amounts</u>		<u>Actual Amounts</u>	Variance with Final Budget Positive (Negative)
	<u>Original</u>	<u>Final</u>		
Beginning budgetary fund balance	<u>\$ 1,361,198</u>	<u>\$ 1,361,198</u>	<u>\$ 1,361,198</u>	<u>\$ --</u>
Resources (inflows)				
Taxes				
Cable TV franchise	18,200	18,200	20,222	2,022
Sales tax	4,616,325	4,616,325	5,129,250	512,925
Utility gross receipts tax	7,469	7,469	8,299	830
Cigarette tax	61,954	61,954	68,838	6,884
Use tax	<u>1,072,580</u>	<u>1,072,580</u>	<u>1,191,755</u>	<u>119,175</u>
Total taxes	<u>5,776,528</u>	<u>5,776,528</u>	<u>6,418,364</u>	<u>641,836</u>
Intergovernmental				
Alcoholic beverage tax	112,325	112,325	124,806	12,481
Grants and donations	<u>151,459</u>	<u>151,459</u>	<u>109,997</u>	<u>(41,462)</u>
Total intergovernmental	<u>263,784</u>	<u>263,784</u>	<u>234,803</u>	<u>(28,981)</u>
Charges for services				
Burial plots, etc.	42,395	42,395	47,105	4,710
Library	<u>466</u>	<u>466</u>	<u>518</u>	<u>52</u>
Total charges for services	<u>42,861</u>	<u>42,861</u>	<u>47,623</u>	<u>4,762</u>
Fines and forfeitures				
Police fines	<u>199,794</u>	<u>199,794</u>	<u>221,937</u>	<u>22,143</u>
Licenses and permits				
Various licenses	<u>93,936</u>	<u>93,936</u>	<u>103,793</u>	<u>9,857</u>
Investment income	<u>47,007</u>	<u>47,007</u>	<u>58,763</u>	<u>11,756</u>
Miscellaneous				
Reimbursements	296,227	296,227	329,141	32,914
Rentals	29,744	29,744	33,049	3,305
Sale of assets	6,120	6,120	6,800	680
Miscellaneous	6,530	6,530	7,256	726
Other Transfers	<u>321,379</u>	<u>321,379</u>	<u>337,947</u>	<u>16,568</u>
Total miscellaneous	<u>660,000</u>	<u>660,000</u>	<u>714,193</u>	<u>54,193</u>

**CITY OF PRYOR CREEK, OKLAHOMA
BUDGETARY COMPARISON SCHEDULE
GENERAL FUND
YEAR ENDED JUNE 30, 2024**

	<u>Budgeted Amounts</u>		<u>Actual Amounts</u>	Variance with Final Budget Positive (Negative)
	<u>Original</u>	<u>Final</u>		
Other financing sources				
Operating net transfers	<u>775,200</u>	<u>775,200</u>	<u>775,200</u>	<u>--</u>
Amounts available for appropriation	<u>9,220,308</u>	<u>9,220,308</u>	<u>9,935,874</u>	<u>715,566</u>
General Government				
General government	1,099,617	1,099,617	619,218	480,399
City Clerk	394,589	394,589	361,975	32,614
City Treasurer	27,531	27,531	26,265	1,266
Planning and Zoning	2,500	2,500	3,046	(546)
Building Inspector	124,433	124,433	137,079	(12,646)
Mayor and Council	<u>208,837</u>	<u>208,837</u>	<u>238,381</u>	<u>(29,544)</u>
Total General Government	<u>1,857,507</u>	<u>1,857,507</u>	<u>1,385,964</u>	<u>471,543</u>
Public Safety				
City Attorney	82,800	82,800	57,580	25,220
Municipal Court	73,318	73,318	55,863	17,455
Police	3,847,231	3,847,231	4,264,339	(417,108)
Animal Control	295,770	295,770	311,445	(15,675)
Civil Defense	20,506	20,506	21,350	(844)
Fire	<u>2,054,248</u>	<u>2,054,248</u>	<u>1,993,461</u>	<u>60,787</u>
Total Public Safety	<u>6,373,873</u>	<u>6,373,873</u>	<u>6,704,038</u>	<u>(330,165)</u>
Cultural Park and Recreation				
Park	291,392	291,392	422,574	(131,182)
Library	530,565	530,565	535,945	(5,380)
Cemetery	<u>166,971</u>	<u>166,971</u>	<u>313,863</u>	<u>(146,892)</u>
Total Cultural Park and Recreation	<u>988,928</u>	<u>988,928</u>	<u>1,272,382</u>	<u>(283,454)</u>
Total Charges to Operations	<u>9,220,308</u>	<u>9,220,308</u>	<u>9,362,384</u>	<u>(142,076)</u>
Ending Budgetary Fund Balances	<u>\$ --</u>	<u>\$ --</u>	573,490	<u>\$ 573,490</u>
Adjustments to reconcile to balance sheet				
Beginning fund balance adjustment			645,722	
Various receivables			1,105,745	
Accrued compensated absences			<u>(46,815)</u>	
Fund Balance			<u>\$ 2,278,142</u>	

OTHER SUPPLEMENTARY INFORMATION

Other supplementary information includes financial statements and schedules not required by the GASB, nor a part of the basic financial statements, but are presented for purposes of additional analysis.

Such statements and schedules include:

Combining Statements - Nonmajor governmental funds

CITY OF PRYOR CREEK, OKLAHOMA
COMBINING BALANCE SHEET
NON-MAJOR GOVERNMENTAL FUNDS
June 30, 2024

SPECIAL REVENUE FUNDS

	E-911 Cash Fund	County-Wide Fire Dept. Funds	Flexible Spending	Cemetery Care Interest Fund	Cemetery Care Fund	Covid Relief Fund	Seizures Fund
ASSETS							
Cash	\$ 37,887	\$ 300,630	\$ 32,877	\$ 17,605	\$ 52,822	\$337,565	\$ 179
Taxes receivable	2	20,971	-	-	-	-	-
Other Receivables	-	-	-	-	-	-	-
Due from other funds	-	-	-	-	-	-	-
Total assets	37,889	321,601	32,877	17,605	52,822	337,565	179
LIABILITIES							
Accounts payable	422	-	-	-	-	-	-
Accrued expenses	-	-	-	-	-	-	-
Due to other funds	-	-	-	-	-	337,565	-
Total liabilities	422	--	--	--	-	337,565	--
FUND BALANCES							
Restricted	37,467	321,601	32,877	17,605	52,822	-	179
Assigned	-	-	-	-	-	-	-
Unassigned	-	-	-	-	-	-	-
Total fund balances	37,467	321,601	32,877	17,605	52,822	-	179
Total liabilities and fund balances	\$ 37,889	\$ 321,601	\$ 32,877	\$ 17,605	\$ 52,822	\$337,565	\$ 179

**CITY OF PRYOR CREEK, OKLAHOMA
COMBINING BALANCE SHEET
NON-MAJOR GOVERNMENTAL FUNDS
June 30, 2024**

SPECIAL REVENUE FUNDS...continued

Library Cash Fund	Donations & Earmarked Monies Fund	Public Works Authority	Hotel & Motel Tax Fund	Fee In-Lieu Fund	Main Street Fund	Economic Trust Development Authority	Police Cash Fund	Special Revenue Funds Total
\$ 31,781	\$ 347,484	\$ 83,823	\$ 81,364	\$37,061	\$ 245,675	\$ 191,365	\$ 30,780	\$ 1,828,898
-	-	-	28,216	-	23,482	-	-	72,671
-	-	-	-	-	-	-	-	-
-	-	3,711	-	-	-	-	-	3,711
<u>31,781</u>	<u>347,484</u>	<u>87,534</u>	<u>109,580</u>	<u>37,061</u>	<u>269,157</u>	<u>191,365</u>	<u>30,780</u>	<u>1,905,280</u>
-	29,503	2,499	5,000	-	-	42,500	-	79,924
-	-	-	-	-	-	-	-	-
-	-	-	-	-	-	-	-	337,565
-	29,503	2,499	5,000	-	-	42,500	--	417,489
31,781	266,930	85,035	104,580	37,061	269,157	148,865	30,780	1,436,740
-	51,051	-	-	-	-	-	-	51,051
-	-	-	-	-	-	-	-	-
<u>31,781</u>	<u>317,981</u>	<u>85,035</u>	<u>104,580</u>	<u>37,061</u>	<u>269,157</u>	<u>148,865</u>	<u>30,780</u>	<u>1,487,791</u>
<u>\$ 31,781</u>	<u>\$ 347,484</u>	<u>\$ 87,534</u>	<u>\$109,580</u>	<u>\$37,061</u>	<u>\$ 269,157</u>	<u>\$ 191,365</u>	<u>\$ 30,780</u>	<u>\$ 1,905,280</u>

**CITY OF PRYOR CREEK, OKLAHOMA
 COMBINING BALANCE SHEET
 NON-MAJOR GOVERNMENTAL FUNDS
 June 30, 2024**

CAPITAL PROJECTS					
PPWA Note Proceeds Fund	Capital Outlay Reserve Fund	Real Property Acquisition Fund	Library Building Fund	Capital Projects Funds Total	Total Non-major Governmental Funds
\$ 1	\$ 300,736	\$ 143,177	\$ 6,348	\$ 450,262	\$ 2,279,160
-	-	-	-	-	72,671
-	-	-	-	-	-
-	-	-	-	-	3,711
<u>1</u>	<u>300,736</u>	<u>143,177</u>	<u>6,348</u>	<u>450,262</u>	<u>2,355,542</u>
-	-	2,375	-	2,375	82,299
-	-	-	-	-	-
-	-	-	-	-	337,565
-	-	2,375	-	2,375	419,864
1	300,736	140,802	6,348	447,887	1,884,627
-	-	-	-	-	51,051
-	-	-	-	-	-
<u>1</u>	<u>300,736</u>	<u>140,802</u>	<u>6,348</u>	<u>447,887</u>	<u>1,935,678</u>
<u>\$ 1</u>	<u>\$ 300,736</u>	<u>\$ 143,177</u>	<u>\$ 6,348</u>	<u>\$ 450,262</u>	<u>\$ 2,355,542</u>

CITY OF PRYOR CREEK, OKLAHOMA
COMBINING STATEMENT OF REVENUES, EXPENDITURES, AND CHANGES IN FUND BALANCES
NON-MAJOR GOVERNMENTAL FUNDS
YEAR ENDED JUNE 30, 2024

	SPECIAL REVENUE FUNDS						
	E-911 Cash Fund	County- Wide Fire Dept. Funds	Flexible Spending Fund	Cemetery Care Interest Fund	Cemetery Care Fund	Covid Relief Fund	Seizures Fund
REVENUES							
Sales tax	\$ -	\$ 123,400	\$ -	\$ -	\$ -	\$ -	\$ -
Other taxes	9,254	-	-	-	-	-	-
Grants/contributions	-	-	-	-	-	-	-
Asset Sales/Ins Reimb	-	-	-	-	-	-	-
Interest	893	-	215	2,082	-	-	1
Franchise taxes	-	-	-	-	-	-	-
Fees and service	-	-	-	-	14,035	-	-
Police Fines	-	-	-	-	-	-	-
Miscellaneous	-	-	-	-	-	-	-
Total revenues	<u>10,147</u>	<u>123,400</u>	<u>215</u>	<u>2,082</u>	<u>14,035</u>	<u>-</u>	<u>1</u>
EXPENDITURES							
Current							
Library	-	-	-	-	-	-	-
Park	-	-	-	-	-	-	-
Police	5,273	-	-	-	-	-	-
Tourism	-	-	-	-	-	-	-
General Gov't	-	-	36,547	-	-	-	-
Fire	-	60,258	-	-	-	-	-
Cemetery	-	-	-	-	-	-	-
Capital outlay	-	-	-	-	-	-	-
Note payments	-	-	-	-	-	-	-
Interest expense	-	-	-	-	-	-	-
Total expenditures	<u>5,273</u>	<u>60,258</u>	<u>36,547</u>	<u>-</u>	<u>-</u>	<u>-</u>	<u>-</u>
Excess (deficiency) of revenues over expenditures	<u>4,874</u>	<u>63,142</u>	<u>(36,332)</u>	<u>2,082</u>	<u>14,035</u>	<u>-</u>	<u>1</u>
OTHER FINANCING SOURCES/USES							
Transfers in	-	-	38,516	-	-	-	-
Transfers out	-	-	-	-	(25,748)	-	-
Total other financing sources and uses	<u>-</u>	<u>-</u>	<u>38,516</u>	<u>-</u>	<u>(25,748)</u>	<u>-</u>	<u>-</u>
Net change in Fund balance	4,874	63,142	2,184	2,082	(11,713)	-	1
Fund balance, Beginning	<u>32,593</u>	<u>258,459</u>	<u>30,693</u>	<u>15,523</u>	<u>64,535</u>	<u>-</u>	<u>178</u>
Fund balance, Ending	<u>\$ 37,467</u>	<u>\$ 321,601</u>	<u>\$ 32,877</u>	<u>\$ 17,605</u>	<u>\$ 52,822</u>	<u>\$ -</u>	<u>\$ 179</u>

CITY OF PRYOR CREEK, OKLAHOMA
COMBINING STATEMENT OF REVENUES, EXPENDITURES, AND CHANGES IN FUND BALANCES
NON-MAJOR GOVERNMENTAL FUNDS
YEAR ENDED JUNE 30, 2024

SPECIAL REVENUE FUNDS...continued

Library Cash Fund	Donations/ Earmarked Monies Fund	Public Works Authority	Hotel & Motel Tax Fund	Fee-In Lieu Fund	Main Street Fund	Economic Trust Development Authority	Police Cash Fund	Special Revenue Funds Total
\$ -	\$ -	\$ -	\$ -	\$ -	\$ 135,451	\$ -	\$ -	\$ 258,851
-	-	-	106,540	-	-	-	-	115,794
9,617	306,182	-	-	-	-	25,850	-	341,649
-	-	-	-	-	-	-	-	-
322	-	1,822	1,088	272	10,262	2,337	786	20,080
-	-	43,290	-	-	-	-	-	43,290
249	-	-	-	-	-	-	-	14,284
-	-	-	-	-	-	-	7,398	7,398
-	-	-	-	-	-	-	-	-
<u>10,188</u>	<u>306,182</u>	<u>45,112</u>	<u>107,628</u>	<u>272</u>	<u>145,713</u>	<u>28,187</u>	<u>8,184</u>	<u>801,346</u>
10,137	-	-	-	-	-	-	-	10,137
-	-	-	-	-	-	-	-	-
-	856	-	-	-	-	-	-	6,129
-	-	-	103,372	-	-	-	-	103,372
-	-	34,804	-	-	-	259,536	-	330,887
-	-	-	-	-	-	-	-	60,258
-	-	-	-	-	-	-	-	-
-	245,322	-	-	-	-	-	3,350	248,672
-	-	-	-	-	-	-	-	-
-	-	-	-	-	-	-	-	-
<u>10,137</u>	<u>246,178</u>	<u>34,804</u>	<u>103,372</u>	<u>-</u>	<u>-</u>	<u>259,536</u>	<u>3,350</u>	<u>759,455</u>
<u>51</u>	<u>60,004</u>	<u>10,308</u>	<u>4,256</u>	<u>272</u>	<u>145,713</u>	<u>(231,349)</u>	<u>4,834</u>	<u>41,891</u>
-	-	-	-	-	-	250,000	-	288,516
-	(64,376)	-	-	-	(250,000)	-	(4,048)	(344,172)
-	(64,376)	-	-	-	(250,000)	250,000	(4,048)	(55,656)
51	(4,372)	10,308	4,256	272	(104,287)	18,651	786	(13,765)
<u>31,730</u>	<u>322,353</u>	<u>74,727</u>	<u>100,324</u>	<u>36,789</u>	<u>373,444</u>	<u>130,214</u>	<u>29,994</u>	<u>1,501,556</u>
<u>\$ 31,781</u>	<u>\$ 317,981</u>	<u>\$ 85,035</u>	<u>\$ 104,580</u>	<u>\$ 37,061</u>	<u>\$ 269,157</u>	<u>\$ 148,865</u>	<u>\$ 30,780</u>	<u>\$ 1,487,791</u>

CITY OF PRYOR CREEK, OKLAHOMA
COMBINING STATEMENT OF REVENUES, EXPENDITURES, AND CHANGES IN FUND BALANCES
NON-MAJOR GOVERNMENTAL FUNDS
YEAR ENDED JUNE 30, 2024

CAPITAL PROJECTS					
PPWA Note Proceeds Fund	Capital Outlay Reserve Fund	Real Property Acquisition Fund	Library Building Fund	Capital Projects Funds Total	Total Non-major Governmental Funds
\$ -	\$ -	\$ -	\$ -	\$ -	\$ 258,851
-	-	-	-	-	115,794
-	-	-	5,000	5,000	346,649
-	-	-	-	-	-
6	6,026	1,018	628	7,678	27,758
-	-	-	-	-	43,290
-	9,900	7,355	2	17,257	31,541
-	-	-	-	-	7,398
-	12,966	-	-	12,966	12,966
<u>6</u>	<u>28,892</u>	<u>8,373</u>	<u>5,630</u>	<u>42,901</u>	<u>844,247</u>
-	-	-	-	-	10,137
-	-	-	-	-	-
-	-	-	-	-	6,129
-	-	-	-	-	103,372
-	-	95,912	-	95,912	426,799
-	-	-	-	-	60,258
-	-	-	-	-	-
-	552,085	18,455	-	570,540	819,212
-	-	-	-	-	-
-	-	-	-	-	-
<u>-</u>	<u>552,085</u>	<u>114,367</u>	<u>-</u>	<u>666,452</u>	<u>1,425,907</u>
<u>6</u>	<u>(523,193)</u>	<u>(105,994)</u>	<u>5,630</u>	<u>(623,551)</u>	<u>(581,660)</u>
-	-	-	-	-	288,516
<u>(592)</u>	<u>-</u>	<u>-</u>	<u>-</u>	<u>(592)</u>	<u>(344,764)</u>
<u>(592)</u>	<u>-</u>	<u>-</u>	<u>-</u>	<u>(592)</u>	<u>(56,248)</u>
(586)	(523,193)	(105,994)	5,630	(624,143)	(637,908)
<u>587</u>	<u>823,929</u>	<u>246,796</u>	<u>718</u>	<u>1,072,030</u>	<u>2,573,586</u>
<u>\$ 1</u>	<u>\$ 300,736</u>	<u>\$ 140,802</u>	<u>\$ 6,348</u>	<u>\$ 447,887</u>	<u>\$ 1,935,678</u>



Report on Internal Control Over Financial Reporting and on Compliance Based on an Audit of Financial Statements Performed in Accordance with Government Auditing Standards

Board of Trustees
City of Pryor Creek, Oklahoma

We have audited in accordance with auditing standards generally accepted in the United States of America and the standards applicable to financial audits contained in *Government Auditing Standards* issued by the Comptroller General of the United States, the financial statements of the governmental activities, the business-type activities, each major fund and the aggregate remaining fund information of City of Pryor Creek, Oklahoma, as of and for the year ended June 30, 2024, which collectively comprise the City of Pryor Creek, Oklahoma's basic financial statements and have issued our report thereon dated February 24, 2026.

Report on Internal Control over Financial Reporting

In planning and performing our audit, we considered the City of Pryor Creek, Oklahoma internal control over financial reporting as a basis for designing our auditing procedures for the purpose of expressing my opinions on the financial statements, but not for the purpose of expressing an opinion on the effectiveness of City of Pryor Creek, Oklahoma's internal control over financial reporting. Accordingly, we do not express an opinion on the effectiveness of the City of Pryor Creek, Oklahoma's internal control over financial reporting.

A *deficiency in internal control* exists when the design or operation of a control does not allow management or employees, in the normal course of performing their assigned functions, to prevent, or detect and correct, misstatements on a timely basis. A *material weakness* is a deficiency, or a combination of deficiencies, in internal control, such that there is a reasonable possibility that a material misstatement of the entity's financial statements will not be prevented, or detected and corrected on a timely basis. A *significant deficiency* is a deficiency, or a combination of deficiencies in the internal control that is less severe than a material weakness, yet important enough to merit attention by those charged by governance.

Our consideration of internal control was for the limited purpose described in the first paragraph of this section and was not designed to identify all deficiencies in internal control over financial reporting that might be deficiencies, significant deficiencies or material weaknesses. Given these limitations, during our audit we did not identify any deficiencies in internal control that we consider to be material weaknesses. However, material weaknesses may exist that have not been identified.

HOOD & ASSOCIATES CPAs, P.C.

WWW.AUDIT.HOODCPAS.COM

Report on Compliance and Other Matters

As part of obtaining reasonable assurance about whether the City of Pryor Creek, Oklahoma financial statements are free of material misstatement, we performed tests of the compliance with certain provisions of laws, regulations, contracts, and grant agreements, noncompliance with which could have a direct and material effect on the determination of financial statement amounts. However, providing an opinion on compliance with those provisions was not an objective of our audit, and accordingly, we do not express such an opinion. The results of our tests disclosed no instances of noncompliance that are required to be reported under *Government Auditing Standards*.

Purpose of this Report

The purpose of this report is solely to describe the scope of our testing of internal control and compliance and the results of that testing, and not to provide an opinion on the effectiveness of the entity's internal control or on compliance. This report is an integral part of an audit performed in accordance with *Government Auditing Standards* in considering the entity's internal control and compliance. Accordingly, this communication is not suitable for any other purpose.



Hood & Associates CPAs, PC

February 24, 2026

**CITY OF PRYOR CREEK, OKLAHOMA
SCHEDULE OF FINDINGS AND RESULTS – PRIOR YEAR
FOR THE YEAR ENDED JUNE 30, 2023**

There were no significant audit findings noted during the audit performed for the fiscal year ended June 30, 2023.

**CITY OF PRYOR CREEK, OKLAHOMA
SCHEDULE OF FINDINGS AND RESULTS – CURRENT YEAR
FOR THE YEAR ENDED JUNE 30, 2024**

There were no significant audit findings noted during the audit performed for the fiscal year ended June 30, 2024.

Statement of Necessity – Deputy Clerk Position

The Deputy Clerk position is essential to maintaining compliance, stability, and daily functionality of the Clerk's Office. This role serves as a cross-trained operational support position that absorbs a wide range of administrative, financial, and records management responsibilities necessary to keep the office running efficiently.

Without this position filled, critical duties such as record retention tracking, inventory management, agreements maintenance, grant documentation support, appropriations tracking, purchase order verification, Worker's Compensation monitoring, title processing, cash receipting, and vault documentation must be redistributed among already fully tasked staff. This increases the risk of delayed processing, compliance gaps, audit findings, and reduced service levels to the public.

Additionally, the Deputy Clerk provides essential front-line coverage by assisting with counter traffic, answering phones, and covering court days and high-volume periods. Without this support, customer service response times and operational continuity are directly impacted.

This position is not supplemental; it is foundational to ensuring accountability, financial accuracy, regulatory compliance, and uninterrupted public service. Filling this vacancy protects internal controls, distributes workload appropriately, and allows the Clerk's Office to continue operating at the level of efficiency and service the community expects.

The Deputy Clerk position is to be backfilled due to the resignation of Sara Catron that took place on February 20th, 2025.

Hannah Morris

Pryor Creek City Clerk

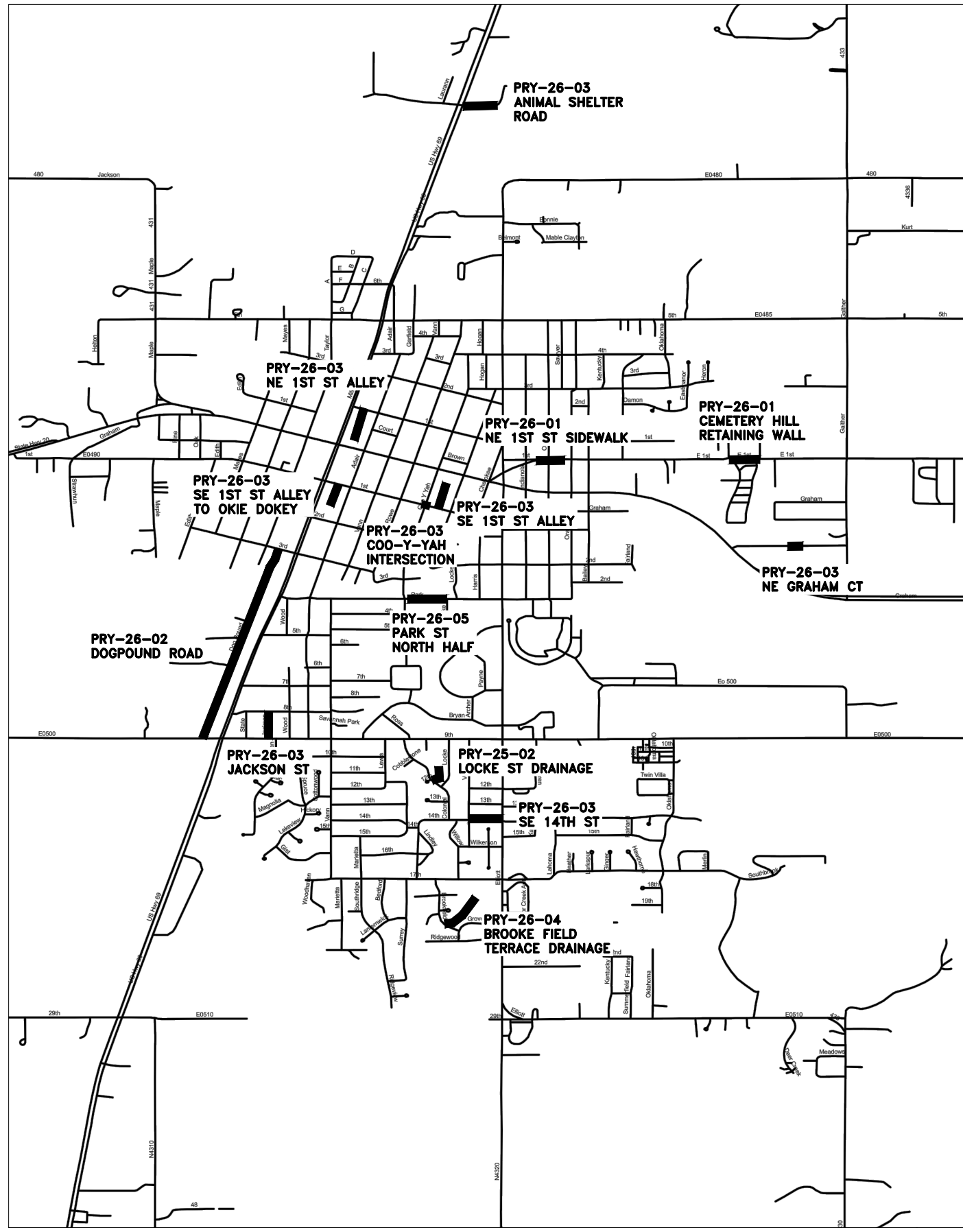

LEGEND

PROPOSED 2026 STREET AND DRAINAGE IMPROVEMENTS 

CITY OF PRYOR STREET MAP
PROPOSED 2026 STREET AND DRAINAGE PROJECTS

ALL SCALES ARE BASED ON 1 INCH. IN THE EVENT THE DRAWINGS ARE PLOTTED AT 1/2 SCALE, ADJUST THE MEASUREMENTS ACCORDING TO THE FOLLOWING SCALE:

Date	Notes	By

Designed	LDB
Checked	LDB
Drawn	MGF
Approved	LDB



INFRASTRUCTURE SOLUTIONS GROUP, LLC
Consulting Engineers
3840 SOUTH 103rd EAST AVE. SUITE 227
TULSA, OKLAHOMA (918) 664-5500

CITY OF PRYOR
PRYOR, OKLAHOMA
PROPOSED 2026 STREET AND DRAINAGE PROJECTS

LOCATION MAP
EXHIBIT

Job:	PRYOR
ID:	PRYOR
Scale:	NTS
Sheet:	1 OF 1

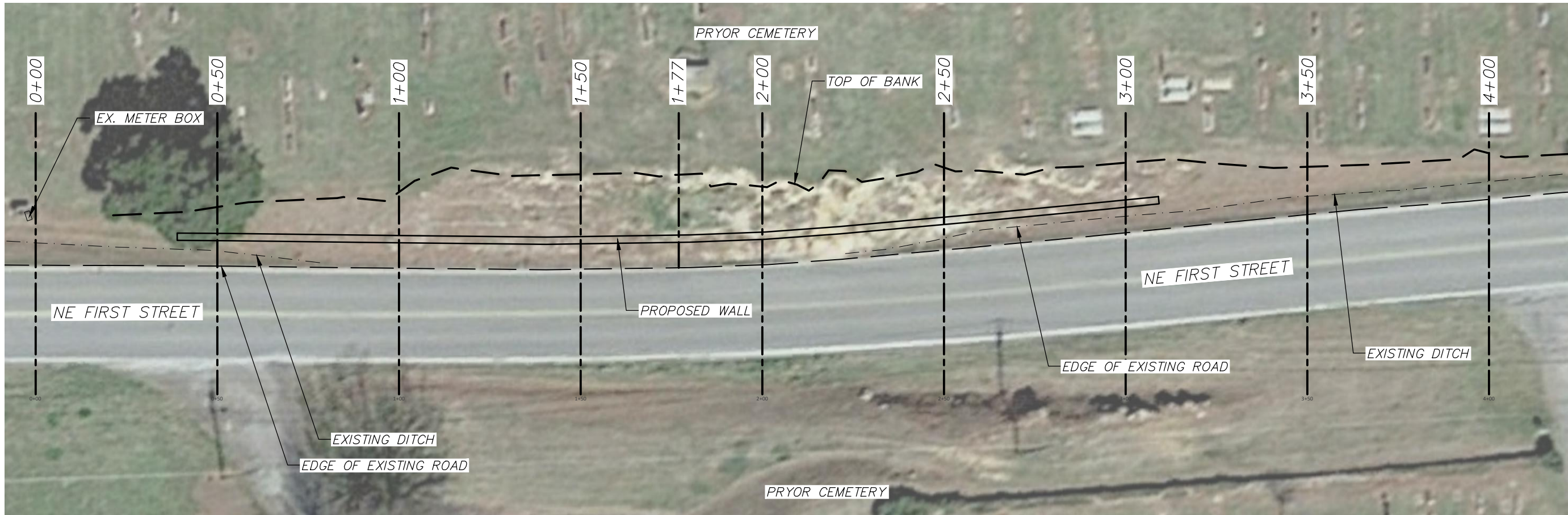

1"=6'

BLOCK DESCRIPTION
 BLOCK DIMENSIONS
 6' LONG x 3' WIDE x 2' TALL
 TOTAL NUMBER OF BLOCKS:
 146
 6" PERFORATED PIPE
 270 L.F.

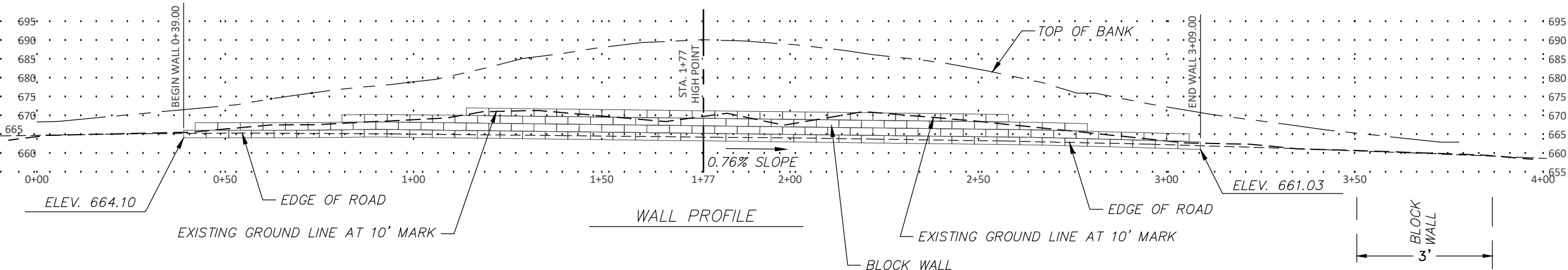

SCALE
 1"=30' H
 1"=3' V

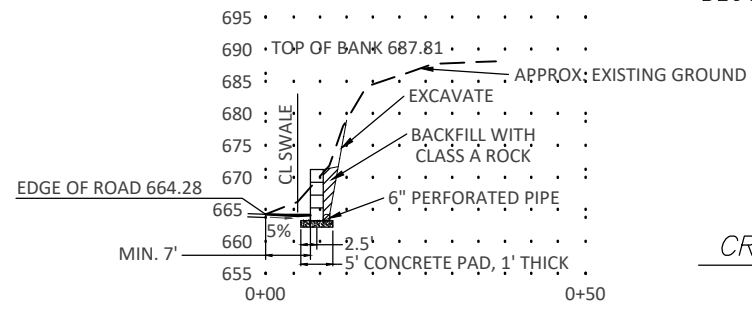

CROSS SECTION @ 1+77

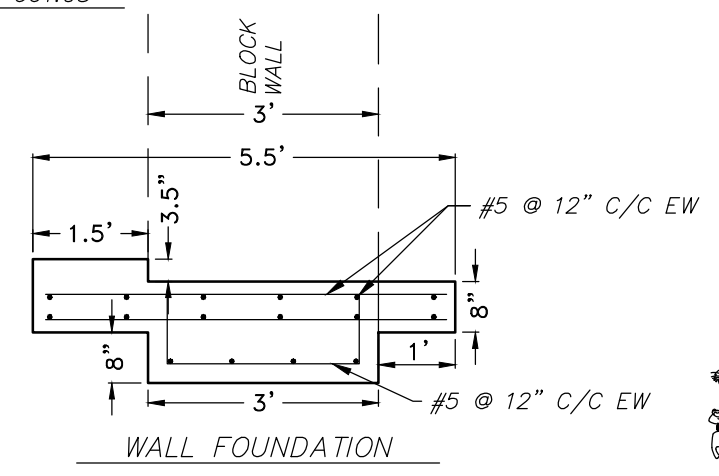

WALL FOUNDATION



12/02/25	CLIENT REVIEW	LDB
Date	Notes	By

Designed	CDP
Checked	LDB
Drawn	CDP
Approved	LDB



CITY OF PRYOR
 PRYOR CREEK, OKLAHOMA
 NE FIRST STREET WALL

SITE PLAN
 WALL PROFILE & WALL CROSS SECTION

Job:	PRY-26-01
Scale:	AS_NOTED
Sheet:	1 OF 1

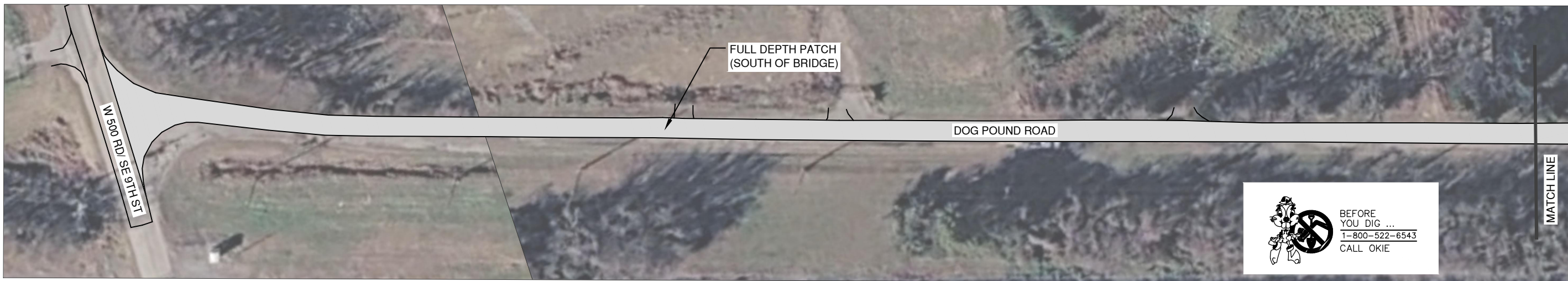
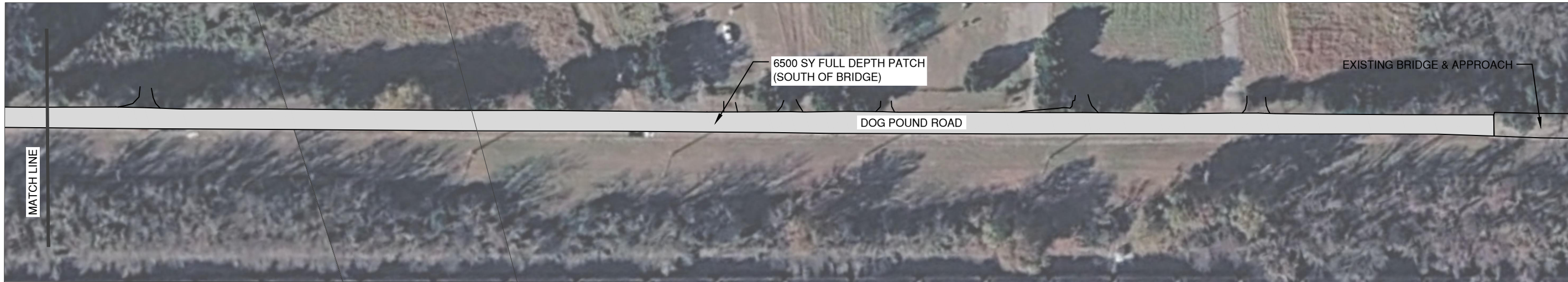

02.10.25	FOR REVIEW	LDB
Date	Notes	By

Designed	CDP
Checked	SAP
Drawn	CDP
Approved	LDB



CITY OF PRYOR CREEK
PRYOR CREEK, OKLAHOMA
DOG POUND ROAD IMPROVEMENTS

DOG POUND ROAD PLAN VIEW
SW 3RD ST TO SE 9TH ST.

Job:	PRY-26-02
Scale:	1"=40'
Sheet:	1 OF 1

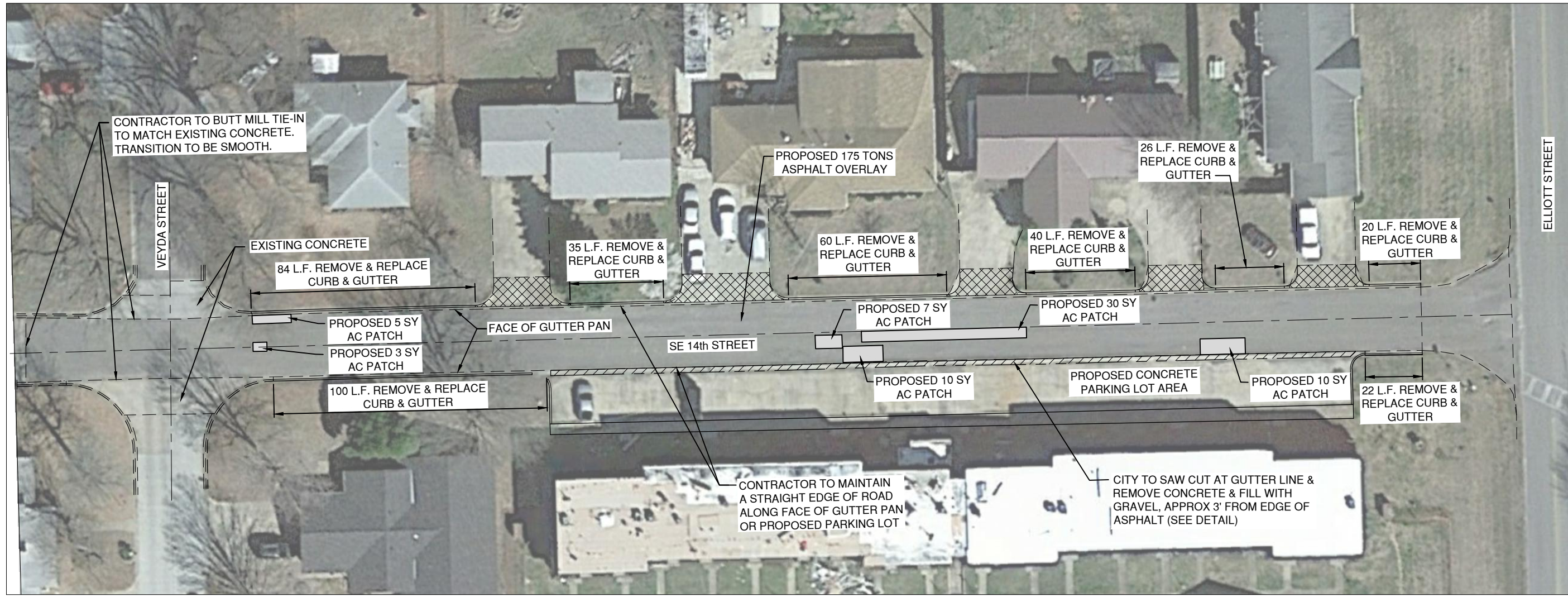

QUANTITY	
REMOVE & REPLACE CURB & GUTTER:	387 L.F.
2" ASPHALT OVERLAY:	175 TONS
AC PATCH:	65 SY
CONCRETE DRIVEWAYS:	145 SY

- LEGEND:
- CONCRETE DRIVEWAY
 - PARKING LOT ASPHALT
 - AC PATCH

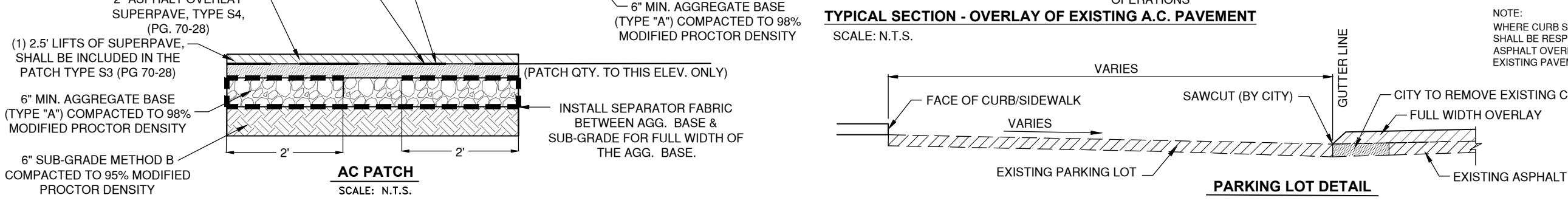
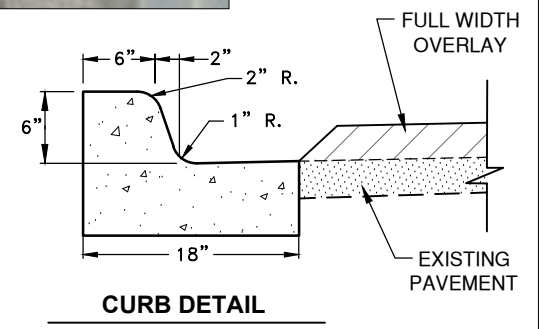
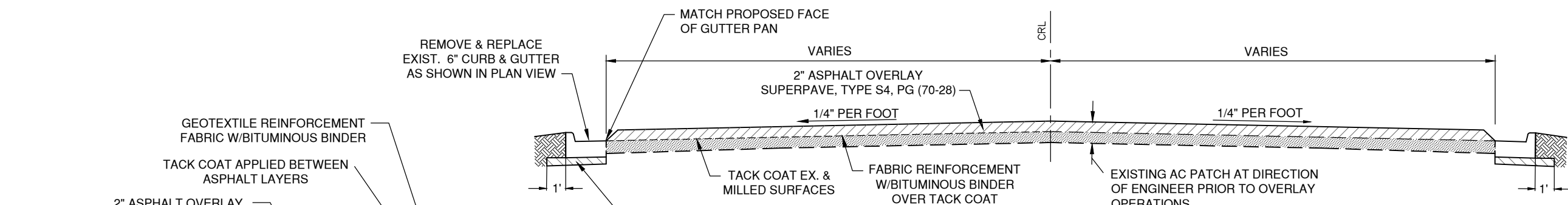

NOTE: WHERE CURB SECTIONS ARE TO BE REMOVED AND REPLACED, THE CONTRACTOR SHALL BE RESPONSIBLE FOR UNIFORM AND DEFINED JOINT LINES WHERE ASPHALT OVERLAYS EXIST ON CONCRETE PAVING. DAMAGED PORTIONS OF EXISTING PAVEMENT SHALL BE REPAIRED AT THE CONTRACTOR'S EXPENSE.

02.10.25	FOR REVIEW	LDB
Date	Notes	By

Designed	CDP
Checked	SAP
Drawn	CDP
Approved	LDB



CITY OF PRYOR CREEK
 PRYOR CREEK, OKLAHOMA
 2026 STREET IMPROVEMENTS

SE 14TH STREET
 PLAN VIEW
 FROM S. ELLIOTT ST. TO VEYDA ST

Job:	PRY-26-03
Scale:	1"=40'
Sheet:	1 OF 1

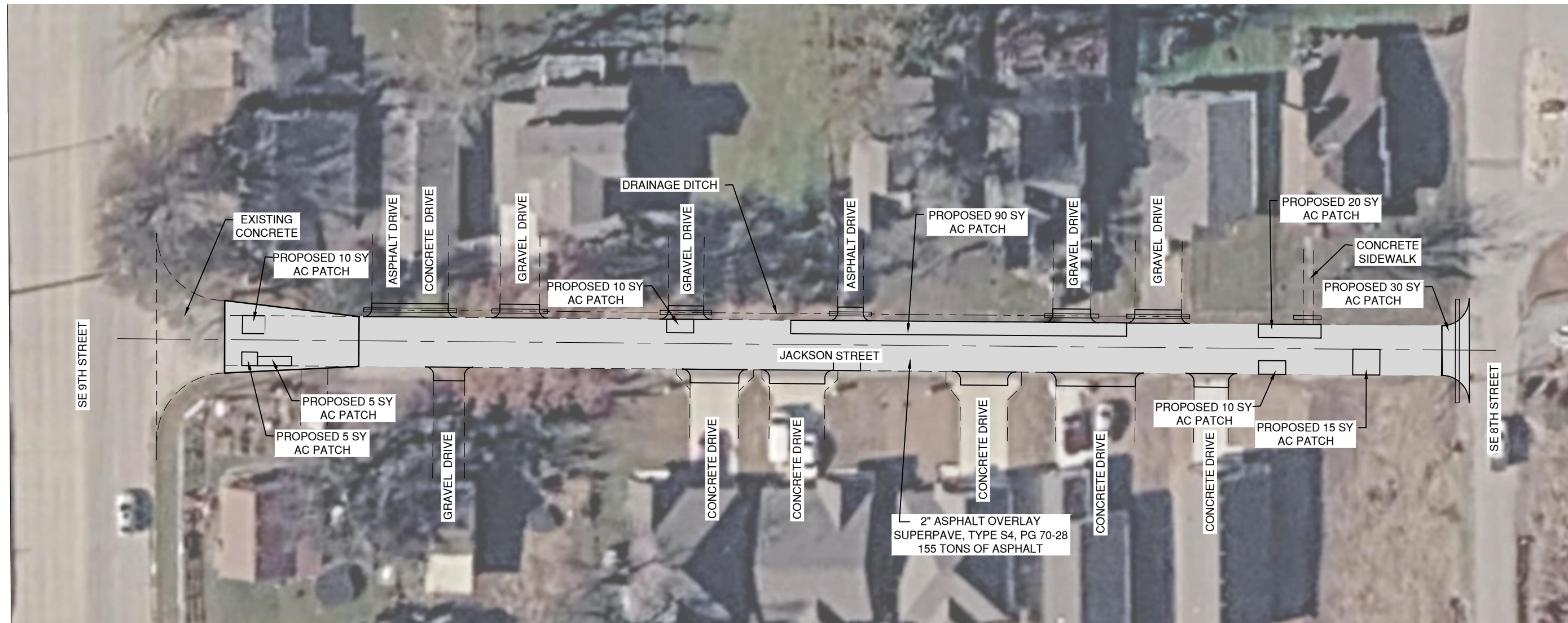
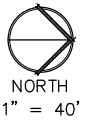

QUANTITIES:
 AC FULL DEPTH PATCH 195 SY
 2" S4 (PG 70-28) ASPHALT PAVEMENT 155 TONS



02.10.25	FOR REVIEW	LDB
Date	Notes	By

Designed	CDP
Checked	SAP
Drawn	CDP
Approved	LDB



CITY OF PRYOR CREEK
 PRYOR CREEK, OKLAHOMA
 2026 STREET IMPROVEMENTS

JACKSON STREET
 PLAN VIEW
 8TH TO 9TH

Job:	PRY-26-03
Scale:	1"=40'
Sheet:	1 OF 1



02.10.25	FOR REVIEW	LDB
Date	Notes	By

Designed	CDP
Checked	SAP
Drawn	CDP
Approved	LDB



CITY OF PRYOR CREEK
 PRYOR CREEK, OKLAHOMA
 2026 STREET IMPROVEMENTS

ALLEY PLAN VIEW
 FROM 1ST STREET TO ALLEY

Job:	PRY-26-03
Scale:	1"=40'
Sheet:	1 OF 1

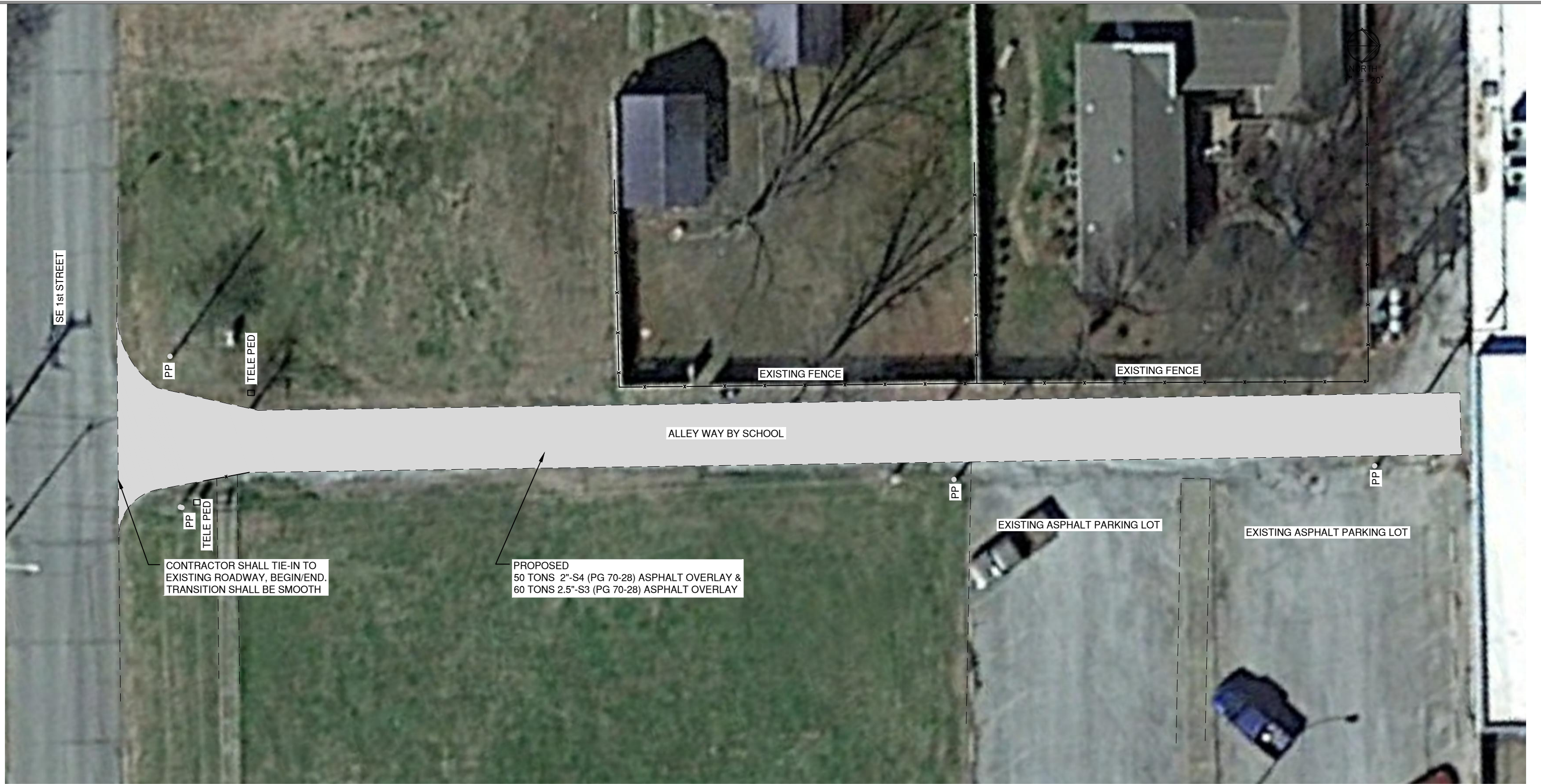

CONTRACTOR SHALL TIE-IN TO EXISTING ROADWAY, BEGIN/END. TRANSITION SHALL BE SMOOTH

PROPOSED
50 TONS 2"-S4 (PG 70-28) ASPHALT OVERLAY &
60 TONS 2.5"-S3 (PG 70-28) ASPHALT OVERLAY



02.10.25	FOR REVIEW	LDB
Date	Notes	By

Designed	CDP
Checked	SAP
Drawn	CDP
Approved	LDB



CITY OF PRYOR CREEK
PRYOR CREEK, OKLAHOMA
2026 STREET IMPROVEMENTS

ALLEY PLAN VIEW
FROM SE 1st STREET NORTH

Job:	PRY-26-03
Scale:	1"=40'
Sheet:	1 OF 1



02/23/2026	EXHIBIT FOR REVIEW	LDB
Date	Notes	By

Designed	_____
Checked	_____
Drawn	_____
Approved	LDB



CITY OF PRYOR CREEK
PRYOR CREEK, OKLAHOMA
2026 STREET IMPROVEMENTS

SE 1ST ST & COO Y YAH ST PLAN VIEW

Job:	PRY-26-03
Scale:	1" = 20'
Sheet:	1 OF 1



NORTH
1" = 40'

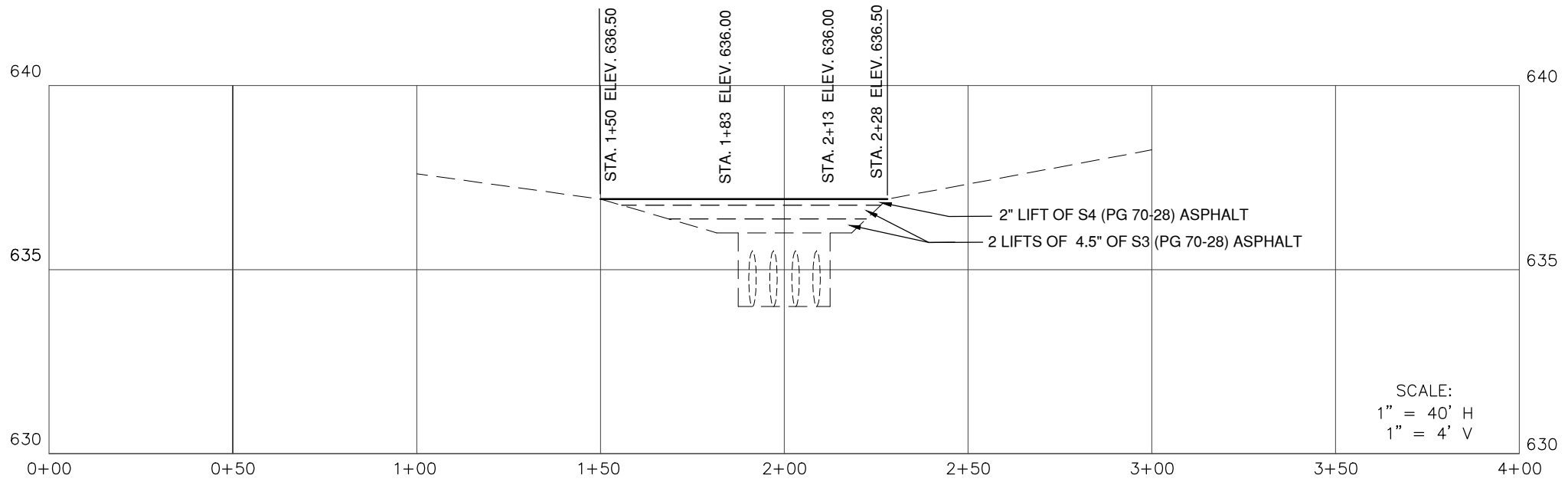

SCALE:
1" = 40' H
1" = 4' V



BEFORE YOU DIG ...
1-800-522-6543
CALL OKIE

02.10.25	FOR REVIEW	LDB
Date	Notes	By

Designed	CDP
Checked	SAP
Drawn	CDP
Approved	LDB



CITY OF PRYOR CREEK
PRYOR CREEK, OKLAHOMA
2026 STREET IMPROVEMENTS

NE GRAHAM COURT
PLAN VIEW

Job:	PRY-26-03
Scale:	1"=40'
Sheet:	1 OF 1



02.10.25	FOR REVIEW	LDB
Date	Notes	By

Designed	CDP
Checked	SAP
Drawn	CDP
Approved	LDB



CITY OF PRYOR CREEK
 PRYOR CREEK, OKLAHOMA
 2026 STREET IMPROVEMENTS

ANIMAL SHELTER ROAD
 PLAN VIEW

Job:	PRY-26-03
Scale:	1"=40'
Sheet:	1 OF 1



"1" ALLEY

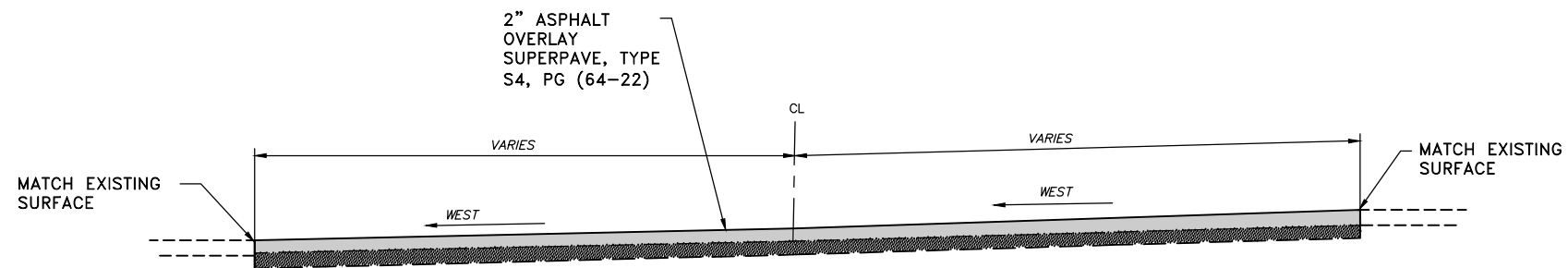

TYPICAL SECTION ALLEY 1 - PROPOSED MILL AND OVERLAY
SCALE: N.T.S.

LEGEND	
EXISTING CURB/EDGE OF ROAD	—————
CONCRETE/BASE REPAIR	■
MILL AND OVERLAY	▨

- NOTE:**
1. MILL ALL ASPHALT ABOVE EXISTING CONCRETE, APPROX. 2"
 2. CONTRACTOR SHALL CLEAN/CLEAR ALL GUTTER AND SWELLS
 3. ALL MILLINGS SHALL BE TAKEN TO THE CITY YARD AND STOCKPILED



ALL SCALES ARE BASED ON 1 INCH. IN THE EVENT THE DRAWINGS ARE PLOTTED AT 1/2 SCALE, ADJUST THE MEASUREMENTS ACCORDING TO THE FOLLOWING SCALE:

02.10.25	FOR REVIEW	LDB
Date	Notes	By

Designed	CDP
Checked	SAP
Drawn	CDP
Approved	LDB



CITY OF PRYOR CREEK
PRYOR CREEK, OKLAHOMA
2026 STREET IMPROVEMENTS

ALLEY PLAN VIEW
FROM 1ST STREET TO OKIE DOKEY

Job:	PRY-26-03
Scale:	1"=40'
Sheet:	1 OF 1



02/23/2026	EXHIBIT FOR REVIEW	LDB
Date	Notes	By

Designed	LDB
Checked	
Drawn	ELH
Approved	



**CITY OF PRYOR CREEK
PRYOR CREEK, OKLAHOMA
BROOKFIELD TERRACE DRAINAGE IMPROVEMENTS**

BROOKFIELD TERRACE DRAINAGE PLAN VIEW

Job:	PRY-26-04
Scale:	1" = 40'
Sheet:	1 OF 1

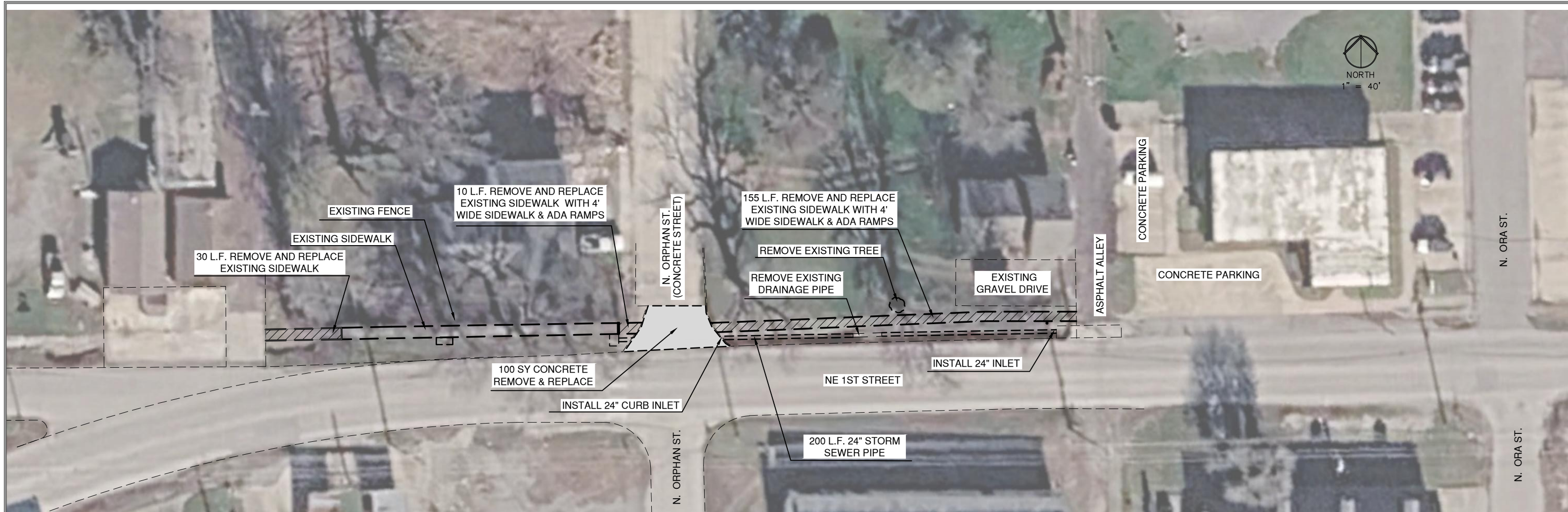

02.10.25	FOR REVIEW	LDB
Date	Notes	By

Designed	CDP
Checked	SAP
Drawn	CDP
Approved	LDB



CITY OF PRYOR CREEK
 PRYOR CREEK, OKLAHOMA
 NE 1st STREET SIDEWALK & DRAINAGE

NE 1st STREET
 PLAN VIEW
 FROM ORA TO ORPHAN

Job:	PRY-26-05
Scale:	1"=40'
Sheet:	1 OF 1

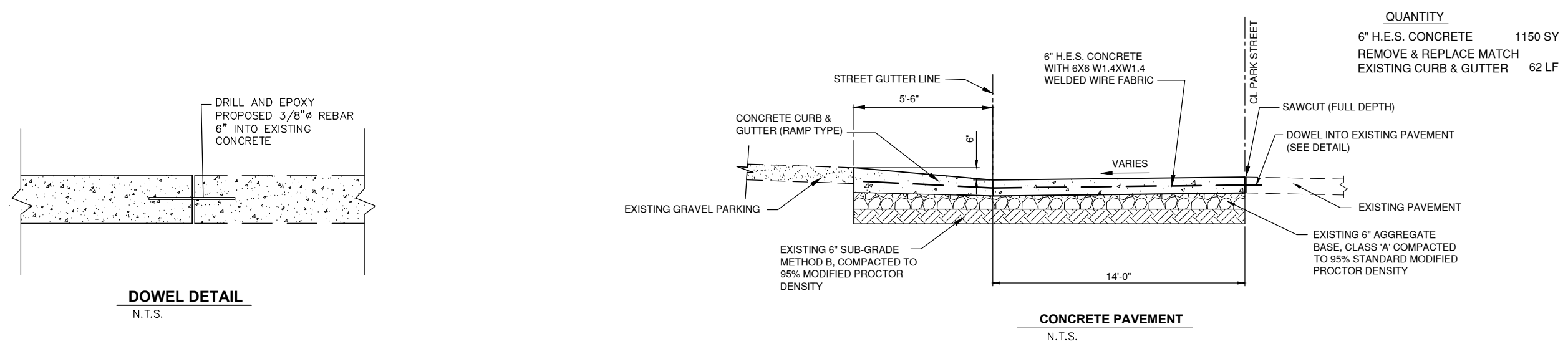

02.10.25	FOR REVIEW	LDB
Date	Notes	By

Designed	CDP
Checked	SAP
Drawn	CDP
Approved	LDB



CITY OF PRYOR CREEK
PRYOR CREEK, OKLAHOMA
2026 STREET IMPROVEMENTS

PARK STREET (NORTH HALF)
PLAN VIEW
FROM S. ELLIOTT ST. TO VEYDA ST

Job:	PRY-26-06
Scale:	1"=40'
Sheet:	1 OF 1

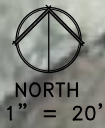

GENERAL NOTES

1. CONTRACTOR TO NOTIFY THE CITY OF PRYOR CREEK & ENGINEER 48 HOURS PRIOR TO CONSTRUCTION AND THE CONTRACTOR SHALL BE RESPONSIBLE FOR SECURING ALL NECESSARY PERMITS PRIOR TO CONSTRUCTION.
2. THE CONTRACTOR WILL BE REQUIRED TO COORDINATE ALL CONSTRUCTION ACTIVITIES WITH THE CITY OF PRYOR CREEK AND THE ENGINEER.
3. CONTRACTOR SHALL BE RESPONSIBLE FOR NOTIFYING PROPERTY OWNERS PRIOR TO ENTRY OF PROPERTY. TEMPORARY FENCING SHALL BE INSTALLED AT FENCE CROSSINGS IMMEDIATELY. PERMANENT FENCING OF EQUAL OR BETTER CONDITION AND STYLE SHALL BE CONSTRUCTED UPON COMPLETION OF CLEAN UP. THIS IS NOT A PAY ITEM AND THE COST SHALL BE INCLUDED IN OTHER ITEMS OF WORK.
4. CONTRACTOR SHALL COORDINATE WITH ALL UTILITY COMPANIES TO HAVE UTILITIES LOCATED AND SHALL BE RESPONSIBLE FOR DAMAGE TO ALL UTILITIES ARISING FROM CONTRACTOR'S WORK REGARDLESS OF BEING SHOWN OR OMITTED FROM THESE DRAWINGS. CONTRACTOR SHALL CALL OKIE BEFORE PERFORMING ANY EXCAVATION.
5. CONTRACTOR SHALL COORDINATE CONSTRUCTION WITH UTILITY COMPANIES AS REQUIRED.
6. THE CONTRACTOR IS ADVISED THAT REQUEST(S) FOR APPROVAL OF ALTERNATE OR EQUAL MATERIALS ON THIS PROJECT MUST BE RECEIVED BY THE ENGINEER A MINIMUM OF TEN (10) CALENDAR DAYS PRIOR TO THE DATE BIDS ARE SCHEDULED TO BE RECEIVED. REQUESTS FOR ALTERNATE OR EQUAL MATERIALS MUST BE FAXED TO THE ENGINEER. VERBAL REQUESTS WILL NOT BE CONSIDERED.
7. WORK ON WEEKENDS OR AFTER HOURS WILL NOT BE ALLOWED UNLESS APPROVED IN ADVANCE BY THE OWNER AND ENGINEER.
8. ALL DIMENSIONS WITH +/- SHALL BE CONFIRMED BY THE CONTRACTOR PRIOR TO ORDERING SUPPLIES, MATERIALS OR COMPLETING THE WORK REQUIRED BY THE DRAWINGS AND THE SPECIFICATIONS.
9. THE CONTRACTOR SHALL MAINTAIN A MARKED-UP SET OF AS-BUILT CONSTRUCTION DRAWINGS. UPON COMPLETION OF THE PROJECT, THE CONTRACTOR SHALL PROVIDE THE MARKED-UP SET OF AS-BUILT CONSTRUCTION DRAWINGS TO THE ENGINEER.

02/11/26	INITIAL SIGN AND SEAL	LDB
Date	Notes	By

Designed	CDP
Checked	LDB
Drawn	CDP
Approved	LDB

INFRASTRUCTURE SOLUTIONS GROUP, LLC
 Consulting Engineers
 3840 SOUTH 103rd EAST AVE. SUITE 227
 TULSA, OKLAHOMA (918)-664-5500

CITY OF PRYOR CREEK
 PRYOR CREEK, OKLAHOMA
 1016 LOCKE STREET ALLEY DRAINAGE

SITE PLAN & GENERAL NOTES

THIS DOCUMENT IS PRELIMINARY IN NATURE AND IS NOT A FINAL, SIGNED & SEALED DOCUMENT

Job:	PRY-26-07
Scale:	NTS
Sheet:	2 OF 2



INFRASTRUCTURE SOLUTIONS GROUP, LLC
Consulting Engineers

WORK ORDER FOR PROFESSIONAL SERVICES
City of Pryor Creek
Project Number PRY-26-01

This will constitute authorization by the City of Pryor Creek (Owner) for Infrastructure Solution Group LLC (Engineer) to proceed with the following described as "Project":

Project Description: Cemetery Retaining Wall Improvements Project

- Prepare Engineering Plans and Specifications, for the referenced project.
- Prepare bid packages, and assist owner in obtaining bids from contractors for the construction of the improvements.
- Prepare contract documents, coordinate contract execution and perform preconstruction conference.
- Provide construction management services including review and approve material submittals, shop drawings, contractors pay estimates, change order requests, and work performed by the contractor.
- Provide Resident Project Representative Services during Construction.
- Perform all work in accordance with STANDARD FORM OF AGREEMENT BETWEEN OWNER AND ENGINEER FOR PROFESSIONAL SERVICES as prepared by ENGINEERS JOINT CONTRACT DOCUMENTS COMMITTEE (EJCDC).

For performance of the services described, the Engineer shall be compensated on a lump sum basis and is broken down as follows;

Fee Summarized below:

Engineering Fee	\$11,000.00
Resident Project Representative Fee	\$ 5,000.00
Design Survey Fee	<u>\$ 2,500.00</u>
Total Fee	\$18,500.00

APPROVED:
City of Pryor Creek

By: _____
Zac Doyle
Mayor

ATTEST:

DATE: _____

ACCEPTED:
Infrastructure Solutions Group LLC,

By: 
Dale Burke
President

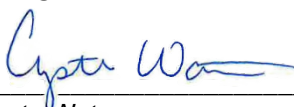
ATTEST:

Crysta Watson
Project Engineer



WORK ORDER FOR PROFESSIONAL SERVICES
City of Pryor Creek
Project Number PRY-26-02

This will constitute authorization by the City of Pryor Creek (Owner) for Infrastructure Solution Group LLC (Engineer) to proceed with the following described as "Project":

Project Description: **Dog Pound Road Base Rehabilitation Project**

- Prepare Engineering Plans and Specifications, for the referenced project.
- Prepare bid packages, and assist owner in obtaining bids from contractors for the construction of the improvements.
- Prepare contract documents, coordinate contract execution and perform preconstruction conference.
- Provide construction management services including review and approve material submittals, shop drawings, contractors pay estimates, change order requests, and work performed by the contractor.
- Provide Resident Project Representative Services during Construction.
- Perform all work in accordance with STANDARD FORM OF AGREEMENT BETWEEN OWNER AND ENGINEER FOR PROFESSIONAL SERVICES as prepared by ENGINEERS JOINT CONTRACT DOCUMENTS COMMITTEE (EJCDC).

For performance of the services described, the Engineer shall be compensated on a lump sum basis and is broken down as follows;

Fee Summarized below:

Engineering Fee	\$32,000.00
Resident Project Representative Fee	\$12,000.00
Design Survey Fee	\$ 5,000.00
Geotechnical Report Fee	<u>\$10,000.00</u>
Total Fee	\$59,000.00

APPROVED:
City of Pryor Creek

By: _____
Zac Doyle
Mayor

ATTEST:

DATE: _____

ACCEPTED:
Infrastructure Solutions Group LLC,

By: 
Dale Burke
President

ATTEST:

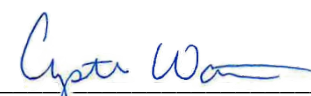

Crysta Watson
Project Engineer



INFRASTRUCTURE SOLUTIONS GROUP, LLC
Consulting Engineers

WORK ORDER FOR PROFESSIONAL SERVICES
City of Pryor Creek
Project Number PRY-26-03

This will constitute authorization by the City of Pryor Creek (Owner) for Infrastructure Solution Group LLC (Engineer) to proceed with the following described as "Project":

Project Description: 2026 Street and Alley Improvements Project

- Prepare Engineering Plans and Specifications, for the referenced project.
- Prepare bid packages, and assist owner in obtaining bids from contractors for the construction of the improvements.
- Prepare contract documents, coordinate contract execution and perform preconstruction conference.
- Provide construction management services including review and approve material submittals, shop drawings, contractors pay estimates, change order requests, and work performed by the contractor.
- Provide Resident Project Representative Services during Construction.
- Perform all work in accordance with STANDARD FORM OF AGREEMENT BETWEEN OWNER AND ENGINEER FOR PROFESSIONAL SERVICES as prepared by ENGINEERS JOINT CONTRACT DOCUMENTS COMMITTEE (EJCDC).

For performance of the services described, the Engineer shall be compensated on a lump sum basis and is broken down as follows;

Fee Summarized below:

Engineering Fee	\$48,000.00
Resident Project Representative Fee	\$17,000.00
Design Survey Fee	<u>\$ 7,500.00</u>
Total Fee	\$72,500.00

APPROVED:
City of Pryor Creek

By: _____
Zac Doyle
Mayor

ATTEST:

ACCEPTED:
Infrastructure Solutions Group LLC,

By: 
Dale Burke
President

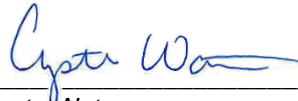
ATTEST:

Crysta Watson
Project Engineer

DATE: March 3rd



WORK ORDER FOR PROFESSIONAL SERVICES
City of Pryor Creek
Project Number PRY-26-04

This will constitute authorization by the City of Pryor Creek (Owner) for Infrastructure Solution Group LLC (Engineer) to proceed with the following described as "Project":

Project Description: Brookfield Terrace Drainage Improvements Project

- Prepare Engineering Plans and Specifications, for the referenced project.
- Prepare bid packages, and assist owner in obtaining bids from contractors for the construction of the improvements.
- Prepare contract documents, coordinate contract execution and perform preconstruction conference.
- Provide construction management services including review and approve material submittals, shop drawings, contractors pay estimates, change order requests, and work performed by the contractor.
- Provide Resident Project Representative Services during Construction.
- Perform all work in accordance with STANDARD FORM OF AGREEMENT BETWEEN OWNER AND ENGINEER FOR PROFESSIONAL SERVICES as prepared by ENGINEERS JOINT CONTRACT DOCUMENTS COMMITTEE (EJCDC).

For performance of the services described, the Engineer shall be compensated on a lump sum basis and is broken down as follows;

Fee Summarized below:

Engineering Fee	\$48,000.00
Resident Project Representative Fee	\$17,000.00
Design Survey Fee	<u>\$ 5,000.00</u>
Total Fee	\$70,000.00

APPROVED:
City of Pryor Creek

By: _____
Zac Doyle
Mayor

ATTEST:

DATE: _____

ACCEPTED:
Infrastructure Solutions Group LLC,

By: 
Dale Burke
President

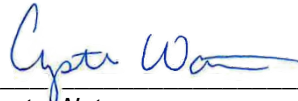
ATTEST:

Crysta Watson
Project Engineer



INFRASTRUCTURE SOLUTIONS GROUP, LLC
Consulting Engineers

WORK ORDER FOR PROFESSIONAL SERVICES
City of Pryor Creek
Project Number PRY-26-05

This will constitute authorization by the City of Pryor Creek (Owner) for Infrastructure Solution Group LLC (Engineer) to proceed with the following described as "Project":

Project Description: **1st Street Sidewalk and Drainage Improvements Project**

- Prepare Engineering Plans and Specifications, for the referenced project.
- Prepare bid packages, and assist owner in obtaining bids from contractors for the construction of the improvements.
- Prepare contract documents, coordinate contract execution and perform preconstruction conference.
- Provide construction management services including review and approve material submittals, shop drawings, contractors pay estimates, change order requests, and work performed by the contractor.
- Provide Resident Project Representative Services during Construction.
- Perform all work in accordance with STANDARD FORM OF AGREEMENT BETWEEN OWNER AND ENGINEER FOR PROFESSIONAL SERVICES as prepared by ENGINEERS JOINT CONTRACT DOCUMENTS COMMITTEE (EJCDC).

For performance of the services described, the Engineer shall be compensated on a lump sum basis and is broken down as follows;

Fee Summarized below:

Engineering Fee	\$11,000.00
Resident Project Representative Fee	\$ 5,000.00
Design Survey Fee	<u>\$ 2,500.00</u>
Total Fee	\$18,500.00

APPROVED:
City of Pryor Creek

By: _____
Zac Doyle
Mayor

ATTEST:

DATE: _____

ACCEPTED:
Infrastructure Solutions Group LLC,

By: 
Dale Burke
President

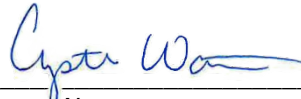
ATTEST:

Crysta Watson
Project Engineer



WORK ORDER FOR PROFESSIONAL SERVICES
City of Pryor Creek
Project Number PRY-26-06

This will constitute authorization by the City of Pryor Creek (Owner) for Infrastructure Solution Group LLC (Engineer) to proceed with the following described as "Project":

Project Description: Park Street Improvements Project

- Prepare Engineering Plans and Specifications, for the referenced project.
- Prepare bid packages, and assist owner in obtaining bids from contractors for the construction of the improvements.
- Prepare contract documents, coordinate contract execution and perform preconstruction conference.
- Provide construction management services including review and approve material submittals, shop drawings, contractors pay estimates, change order requests, and work performed by the contractor.
- Provide Resident Project Representative Services during Construction.
- Perform all work in accordance with STANDARD FORM OF AGREEMENT BETWEEN OWNER AND ENGINEER FOR PROFESSIONAL SERVICES as prepared by ENGINEERS JOINT CONTRACT DOCUMENTS COMMITTEE (EJCDC).

For performance of the services described, the Engineer shall be compensated on a lump sum basis and is broken down as follows;

Fee Summarized below:

Engineering Fee	\$21,000.00
Resident Project Representative Fee	\$ 9,000.00
Design Survey Fee	<u>\$ 2,500.00</u>
Total Fee	\$32,500.00

APPROVED:
City of Pryor Creek

By: _____
Zac Doyle
Mayor

ATTEST:

DATE: _____

ACCEPTED:
Infrastructure Solutions Group LLC,

By: 
Dale Burke
President

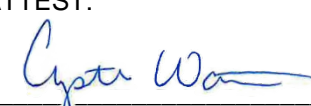
ATTEST:

Crysta Watson
Project Engineer



INFRASTRUCTURE SOLUTIONS GROUP, LLC
Consulting Engineers

WORK ORDER FOR PROFESSIONAL SERVICES
City of Pryor Creek
Project Number PRY-26-07

This will constitute authorization by the City of Pryor Creek (Owner) for Infrastructure Solution Group LLC (Engineer) to proceed with the following described as "Project":

Project Description: Locke Street Alley Drainage Improvements Project

- Prepare Engineering Plans and Specifications, for the referenced project.
- Prepare bid packages, and assist owner in obtaining bids from contractors for the construction of the improvements.
- Prepare contract documents, coordinate contract execution and perform preconstruction conference.
- Provide construction management services including review and approve material submittals, shop drawings, contractors pay estimates, change order requests, and work performed by the contractor.
- Provide Resident Project Representative Services during Construction.
- Perform all work in accordance with STANDARD FORM OF AGREEMENT BETWEEN OWNER AND ENGINEER FOR PROFESSIONAL SERVICES as prepared by ENGINEERS JOINT CONTRACT DOCUMENTS COMMITTEE (EJCDC).

For performance of the services described, the Engineer shall be compensated on a lump sum basis and is broken down as follows;

Fee Summarized below:

Engineering Fee	\$1,300.00
Resident Project Representative Fee	\$ 500.00
Design Survey Fee	<u>\$1,000.00</u>
Total Fee	\$2,800.00

APPROVED:
City of Pryor Creek

By: _____
Zac Doyle
Mayor

ATTEST:

DATE: _____

ACCEPTED:
Infrastructure Solutions Group LLC,

By: 
Dale Burke
President

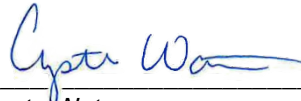
ATTEST:

Crysta Watson
Project Engineer



Opinion of Probable Construction Cost

City of Pryor Creek

February 22, 2026

Page 1 of 1

Projects

Proposed 2026 Street, Alley, Sidewalk and Drainage Improvements

Project Name		Total Project Cost	Construction Cost	Engineering/Survey Geotechnical Fees
PRY-26-01	Cemetery Hill Retaining Wall Improvements	\$ 99,590.00	\$ 83,590.00	\$ 18,500.00
PRY-26-02	Dog Pound Road Base Rehabilitation (3rd Street to 9th Street)	\$ 368,500.00	\$ 309,500.00	\$ 59,000.00
PRY-26-03	2026 Street and Alley Improvements (14th, Jackson, 3-Alleys, 1st and Coo Y Yah, Graham, Animal Shelter)	\$ 583,850.00	\$ 511,350.00	\$ 72,500.00
PRY-26-04	Brookfield Terrace Drainage Improvements	\$ 588,750.00	\$ 523,750.00	\$ 70,000.00
PRY-26-05	Sidewalks along 1st Street with Drainage Improvements (Alley West of Ora Street past Orphan Street)	\$ 99,320.00	\$ 80,820.00	\$ 18,500.00
PRY-26-06	Park Street Improvements (North Side)	\$ 218,000.00	\$ 188,000.00	\$ 32,500.00
PRY-26-07	Locke Street Alley Drainage Improvements	\$ 12,350.00	\$ 9,550.00	\$ 2,800.00
		\$ 1,970,360.00	\$ 1,706,560.00	\$ 273,800.00

The costs shown are estimated costs and represent our best judgment; these estimated costs are not guarantees that the actual costs will not vary from these estimated costs.



INFRASTRUCTURE SOLUTIONS GROUP, LLC
Consulting Engineers

Opinion of Probable Construction Cost

City of Pryor

February 14, 2026

Page 1 of 1

Project # PRY-26-01

Cemetery Hill Retaining Wall Improvements

Item	Description	Unit	Qty	Unit Price	Total Price
1	6'x3'x2' Blocks (Decorative Front, Locking)	EA	146	\$ 65.00	\$ 9,490.00
2	Installation Blocks	EA	146	\$ 50.00	\$ 7,300.00
3	Blocks Footing	LF	270	\$ 40.00	\$ 10,800.00
4	Earthwork	LS	1	\$ 15,000.00	\$ 15,000.00
5	Drainage System	LF	270	\$ 100.00	\$ 27,000.00
Contingency 20%					\$ 14,000.00
Construction Total					\$ 83,590.00
Engineering Fees					\$ 11,000.00
Resident Project Representative					\$ 5,000.00
Design Survey					\$ 2,500.00
Total Project Cost					\$ 99,590.00

The costs shown are estimated costs and represent our best judgment; however these estimated costs are not guarantees that the actual costs will not vary from these estimated costs.



Opinion of Probable Construction Cost

City of Pryor

February 12, 2026

Page 1 of 1

Project # PRY-26-02

Dog Pound Road Base Rehabilitation (3rd Street to 9th Street)

Item	Description	Unit	Qty	Unit Price	Total Price
1	Mobilization / Minimal Traffic Control	LS	1	\$ 15,000.00	\$ 15,000.00
2	Reclaim Existing Asphalt into Subgrade	SY	8,500	\$ 2.50	\$ 21,250.00
3	Estimated CKD Supply (~6%)	TON	200	\$ 65.00	\$ 13,000.00
4	8" Subgrade	SY	8,500	\$ 7.50	\$ 63,750.00
5	6" Aggregate Base	SY	8,500	\$ 17.00	\$ 144,500.00
Contingency ~20%					\$ 52,000.00
Construction Total					\$ 309,500.00
Engineering Fees					\$ 32,000.00
Resident Project Representative					\$ 12,000.00
Geotechnical Report					\$ 10,000.00
Design Survey					\$ 5,000.00
Total Project Cost					\$ 368,500.00

The costs shown are estimated costs and represent our best judgment; however these estimated costs are not guarantees that the actual costs will not vary from these estimated costs.



Opinion of Probable Construction Cost

City of Pryor

February 14, 2026

Page 1 of 1

Project # PRY-26-03

2026 Street and Alley Improvements (14th, Jackson, 3-Alleys, 1st and Coo Y Yah, Graham, Animal Shelter)

Item	Description	Unit	Qty	Unit Price	Total Price
SE 14th Street (S. Elliott to Vedya Street)					
1	2" Superpave S4 Overlay Course Asphalt	Ton	175	\$ 140.00	\$ 24,500.00
2	AC Full Depth Patch	SY	65	\$ 200.00	\$ 13,000.00
3	Remove and Replace Curb & Gutter	LF	387	\$ 100.00	\$ 38,700.00
4	6" Concrete Driveway Remove & Replace to ROW or Joint	SY	145	\$ 200.00	\$ 29,000.00
Sub Total					\$ 105,200.00
Jackson Street (8th Street to 9th Street)					
1	2" Superpave S4 Overlay/Traffic Course Asphalt	Ton	155	\$ 140.00	\$ 21,700.00
2	AC Full Depth Patch	SY	195	\$ 200.00	\$ 39,000.00
3	Drainage Improvements	LS	1	\$ 25,000.00	\$ 25,000.00
Sub Total					\$ 85,700.00
Alley Improvements (Between N Mill Street and N Adair Street from NE 1st Street South Approximately 330 feet)					
1	2" Superpave S4 Overlay/Traffic Course Asphalt	Ton	85	\$ 140.00	\$ 11,900.00
2	2.5" Superpave S3 Base Course Asphalt	Ton	30	\$ 140.00	\$ 4,200.00
3	4" Asphalt/Gravel Milling	SY	350	\$ 25.00	\$ 8,750.00
4	6" Aggregate Base	SY	350	\$ 40.00	\$ 14,000.00
5	Drainage Improvements	LS	1	\$ 10,000.00	\$ 10,000.00
Sub Total					\$ 48,850.00
Alley Improvements (Between S Coo Y Yah Street and S Hogan Street from SE 1st Street North Approximately 250 feet)					
1	2" Superpave S4 Overlay/Traffic Course Asphalt	Ton	50	\$ 140.00	\$ 7,000.00
2	2.5" Superpave S3 Base Course Asphalt	Ton	60	\$ 140.00	\$ 8,400.00
3	6" Aggregate Base	SY	520	\$ 40.00	\$ 20,800.00
4	Drainage Improvements	LS	1	\$ 35,000.00	\$ 35,000.00
Sub Total					\$ 71,200.00
SE 1st Street and Coo Y Yah Street North Intersection Crossing Improvements					
1	Cross Drain	SY	160	\$ 200.00	\$ 32,000.00
Sub Total					\$ 32,000.00
NE Graham Court Bridge Improvements					
1	2" Superpave S4 Overlay/Traffic Course Asphalt	Ton	30	\$ 140.00	\$ 4,200.00
2	4.5" Superpave S3 Base Course Asphalt (2 Lifts)	Ton	120	\$ 140.00	\$ 16,800.00
Sub Total					\$ 21,000.00
Animal Shelter Access Road					
1	2" Superpave S4 Overlay/Traffic Course Asphalt	Ton	100	\$ 140.00	\$ 14,000.00
2	2.5" Superpave S3 Base Course Asphalt	Ton	120	\$ 140.00	\$ 16,800.00
Sub Total					\$ 30,800.00
Alley Improvements (North Half of Alley East of HWY 69 between SE 1st and SE 2nd)					
1	2" Superpave S4 Overlay/Traffic Course Asphalt	Ton	45	\$ 140.00	\$ 6,300.00
2	2" Mill	SY	420	\$ 15.00	\$ 6,300.00
3	AC Full Depth Patch	SY	90	\$ 200.00	\$ 18,000.00
Sub Total					\$ 30,600.00
Contingency 20%					\$ 86,000.00
Construction Total					\$ 511,350.00
Engineering Fees					\$ 48,000.00
Resident Project Representative					\$ 17,000.00
Design Survey					\$ 7,500.00
Total Project Cost					\$ 583,850.00

The costs shown are estimated costs and represent our best judgment; however these estimated costs are not guarantees that the actual costs will not vary from these estimated costs.



Opinion of Probable Construction Cost

City of Pryor

February 14, 2026

Page 1 of 1

Project # PRY-26-04

Brookfield Terrace Drainage Improvements

Item	Description	Unit	Qty	Unit Price	Total Price
1	Curb inlets	EA	3	\$ 500.00	\$ 1,500.00
2	Headwall	EA	4	\$ 1,500.00	\$ 6,000.00
3	Double Row Street Drainage Culverts (Polypropylene)	LF	45	\$ 100.00	\$ 4,500.00
4	Street Drainage Culverts (Polypropylene)	LF	30	\$ 75.00	\$ 2,250.00
5	Retaining Wall	LF	500	\$ 450.00	\$ 225,000.00
6	Earthwork	LS	1	\$ 50,000.00	\$ 50,000.00
7	Mobilization	LS	1	\$ 10,000.00	\$ 10,000.00
8	Concrete Flume	LF	550	\$ 150.00	\$ 82,500.00
9	Tree and Stump Removal	EA	20	\$ 2,000.00	\$ 40,000.00
10	Septic System Relocation	EA	4	\$ 3,500.00	\$ 14,000.00
Contingency 20%					\$ 88,000.00
Construction Total					\$523,750.00
Engineering Fees					\$ 48,000.00
Resident Project Representative					\$ 17,000.00
Design Survey					\$ 5,000.00
Total Project Cost					\$ 588,750.00

The costs shown are estimated costs and represent our best judgment; however these estimated costs are not guarantees that the actual costs will not vary from these estimated costs.



Opinion of Probable Construction Cost

City of Pryor Creek

February 14, 2026

Page 1 of 1

Project # PRY-26-05

Sidewalks along 1st Street with Drainage Improvements (Alley West of Ora Street past Orphan Street)

Item	Description	Unit	Qty	Unit Price	Total Price
1	4' Wide 4" Concrete Sidewalk	LF	195	\$ 60.00	\$ 11,700.00
2	Grading / Earthwork for Sidewalk	LF	195	\$ 16.00	\$ 3,120.00
3	6" Concrete Intersection Paving 1st Street & Orphan Street	SY	100	\$ 175.00	\$ 17,500.00
4	ADA Compliant Ramps	EA	3	\$ 1,000.00	\$ 3,000.00
5	Tactile Walking Surface Indicator at Crosswalks	EA	4	\$ 350.00	\$ 1,400.00
6	Crosswalk Striping	LF	25	\$ 100.00	\$ 2,500.00
7	Crosswalk Signage	EA	4	\$ 400.00	\$ 1,600.00
8	24" HP Storm Pipe	LF	200	\$ 100.00	\$ 20,000.00
9	24" HP Storm Pipe Connections	EA	2	\$ 500.00	\$ 1,000.00
10	24" Area Inlets	EA	2	\$ 3,500.00	\$ 7,000.00
Contingency 20%					\$ 12,000.00
Total Construction Cost					\$ 80,820.00
Engineering Fee					\$ 11,000.00
Resident Project Representative					\$ 5,000.00
Survey Fee					\$ 2,500.00
Total Project Cost					\$ 99,320.00

The costs shown are estimated costs and represent our best judgment; however these estimated costs are not guarantees that the actual costs will not vary from these estimated costs.

		Opinion of Probable Construction Cost			
		City of Pryor			
		February 14, 2026			
		Page 1 of 1		Project # PRY-26-06	
Park Street Improvements (North Side)					
Item	Description	Unit	Qty	Unit Price	Total Price
1	Mobilization	LS	1	\$ 12,000.00	\$ 12,000.00
2	Traffic Control	LS	1	\$ 4,000.00	\$ 4,000.00
3	Earthwork & Demolition	SY	1,150	\$ 35.00	\$ 40,250.00
4	Concrete Curb and Gutter (Ramp Type)	LF	62	\$ 50.00	\$ 3,100.00
5	PC Concrete for Pavement (Placement)	SY	1,150	\$ 45.00	\$ 51,750.00
6	PC Concrete for Pavement	CY	170	\$ 220.00	\$ 37,400.00
7	Concrete Joint Sealing	LF	1,500	\$ 5.00	\$ 7,500.00
Contingency 20%					\$ 32,000.00
Construction Total					\$188,000.00
Engineering Fees					\$ 21,000.00
Resident Project Representative					\$ 9,000.00
Design Survey					\$ 2,500.00
Total Project Cost					\$ 218,000.00
<p><i>The costs shown are estimated costs and represent our best judgment; however these estimated costs are not guarantees that the actual costs will not vary from these estimated costs.</i></p>					



INFRASTRUCTURE SOLUTIONS GROUP, LLC
Consulting Engineers

Opinion of Probable Construction Cost

City of Pryor

February 14, 2026

Page 1 of 1

Project # PRY-26-07

Locke Street Alley Drainage Improvements

Item	Description	Unit	Qty	Unit Price	Total Price
1	Earthen Flume	LF	250	\$ 25.00	\$ 6,250.00
2	Sod	SF	1,000	\$ 1.30	\$ 1,300.00
Contingency 20%					\$ 2,000.00
Construction Total					\$ 9,550.00
Engineering Fees					\$ 1,300.00
Resident Project Representative					\$ 500.00
Design Survey					\$ 1,000.00
Total Project Cost					\$ 12,350.00

The costs shown are estimated costs and represent our best judgment; however these estimated costs are not guarantees that the actual costs will not vary from these estimated costs.

ORDINANCE NO. 2026-__

AN ORDINANCE OF THE CITY OF PRYOR CREEK, OKLAHOMA GRANTING A NON-EXCLUSIVE PERMIT TO CLARITY TELECOM, LLC (D/B/A BLUEPEAK) FOR THE CONSTRUCTION AND OPERATION OF A CABLE SYSTEM.

WHEREAS, the City's role as manager of public rights-of-way and easements and as a regulator of cable service requires it to maintain a fair and level playing field for all such service providers; and

WHEREAS, the City and Bluepeak have determined that it is in the best interest of all parties, including the citizens of City, that Bluepeak be granted the right to construct and operate a cable system to provide cable services within the City; and

WHEREAS, the City Council of Pryor Creek has relied on Bluepeak's representations and has considered all information presented to it by Bluepeak, by City staff, and the public, and has determined that Bluepeak has the technical, legal, and financial ability to construct and operate a cable system and to provide cable services; and

WHEREAS, Article VIII, Section 71 of the Charter of the City of Pryor Creek requires that no franchise be granted, extended, or renewed without approval of a majority of the qualified electors voting thereon at a regular or special election;

WHEREAS, The Cable Communications Policy Act of 1984, 47 U.S.C. §§ 521-573, establishes a comprehensive federal framework governing cable television systems, provides that franchises are to be granted by a local 'franchising authority,' and expressly preempts inconsistent local provisions pursuant to § 556(c);

WHEREAS, 47 U.S.C. § 522(10) defines the term "franchising authority" as any governmental entity empowered by Federal, State, or local law to grant a franchise.

WHEREAS, The City Council has reviewed the Charter, the proposed Bluepeak franchise agreement, and applicable federal law, and finds that the Charter's election requirement conflicts with The Cable Communications Policy Act of 1984 as applied to cable television systems and is therefore preempted;

WHEREAS, based upon such representations, the City Council of Pryor Creek has determined that it would be in the best interests of the City to grant Bluepeak a non-exclusive permit to construct, install, maintain, and operate a cable system in the City, subject to the terms and conditions set forth herein and applicable federal, state, and municipal statutes, regulations and ordinances, is consistent with the public interest.

NOW, THEREFORE, BE IT ORDAINED BY THE CITY COUNCIL OF PRYOR CREEK THAT THE FOLLOWING ORDINANCE BE ENACTED:

SECTION 1: Definition of Terms

For the purpose of this ordinance (the “Ordinance”), the following terms, phrases, words and abbreviations shall have the meanings ascribed to them below. When not inconsistent with the context, words used in the present tense include the future tense, words in the plural number include the singular number, and words in the singular number include the plural number:

(A) “Affiliate” means an entity which owns or controls, is owned or controlled by, or is under common ownership or control with Bluepeak.

(B) “Basic Cable” means the tier of Cable Service regularly provided to all Subscribers that includes the retransmission of local broadcast television signals.

(C) “Bluepeak” means Clarity Telecom, LLC (D/B/A Bluepeak), or the lawful successor, transferee, or assignee thereof.

(D) “Cable Service” means (i) the one-way transmission to Subscribers of Video Programming or other programming service, and (ii) Subscriber interaction, if any, which is required for the selection or use of such Video Programming or other programming service.

(E) “Cable System” means a facility, consisting of a set of closed transmission paths and associated signal generation, reception, and control equipment or other equipment that is designed to provide Cable Service or other service to Subscribers. Bluepeak’s cable system will be a fiber to the home/business network within the City utilizing the latest GPON/XGS PON infrastructure. Services available over the Cable System will include an Internet Protocol video service that includes the channels and programs commonly offered in the video marketplace in the City, as well as an integrated over-the-top (OTT) marketplace providing consumers access to content from providers like Netflix, Amazon Prime, Hulu, HBO max, etc. In addition, the Cable System will be capable of delivering high speed, symmetrical, bi- directional Internet to residential customers ranging from 1 to 2 Gbps and upwards of 10 Gbps for business customers.

(F) “City” means the City of PRYOR CREEK, Oklahoma, a municipal corporation.

(G) “FCC” means Federal Communications Commission, or successor governmental entity thereto.

(H) “Permit” means the initial authorization, or renewal thereof, issued by the City, regardless of whether such authorization is designated as a franchise, permit, license, resolution, contract, certificate, or otherwise, which authorizes construction and operation of the Cable System for the purpose of offering Cable Service or other service to Subscribers.

(I) “Person” means an individual, partnership, association, joint stock company, trust corporation, or governmental entity.

(J) “Public Way” means the surface of, and the space above and below, any public street, highway, freeway, bridge, land path, alley, court, boulevard, sidewalk, parkway, way, lane, public way, drive, circle, or other public right-of-way, including, but not limited to, public

utility easements, dedicated utility strips, or rights-of-way dedicated for compatible uses and any temporary or permanent fixtures or improvements located thereon now or hereafter held by City in the Service Area which shall entitle City and Bluepeak to the use thereof for the purpose of installing, operating, repairing, and maintaining the Cable System. “Public Way” also means any easement now or hereafter held by City within the Service Area for the purpose of public travel, or for utility or public service use dedicated for compatible uses, and shall include other easements or rights-of-way as shall within their proper use and meaning entitle City and Bluepeak to the use thereof for the purposes of installing or transmitting Bluepeak’s Cable Service or other service over poles, wires, cables, conductors, ducts, conduits, vaults, manholes, pedestals, amplifiers, appliances, attachments, and other related property or equipment as may be necessary or appurtenant to the Cable System.

(K) “Service Area” means the present municipal boundaries of the City and all areas annexed into the City in the future.

(L) “Subscriber” means a user of the Cable System who lawfully receives Cable Service with Bluepeak’s express permission.

(M) “Video Programming” means programming provided by, or generally considered comparable to programming provided by, a television broadcast station.

SECTION 2: Grant of Permit

2.1 **Grant.** City hereby grants to Bluepeak a nonexclusive Permit authorizing Bluepeak to construct and operate a Cable System and offer Cable Service and other service in, along, among, upon, across, above, over, under, or in any manner connected with Public Ways within the Service Area and for that purpose to erect, install, construct, repair, replace, reconstruct, maintain, or retain in, on, over, under, upon, across, or along any Public Way and all extensions thereof and additions thereto, such poles, wires, cables, conductors, ducts, conduits, vaults, manholes, pedestals, amplifiers, appliances, attachments, and other related property or equipment as may be necessary or appurtenant to the Cable System. Nothing in this Permit shall be construed to prohibit Bluepeak from offering any service over its Cable System that is not prohibited by applicable law.

2.2 **Term.** The Permit granted pursuant to this Ordinance shall be for a term of twenty (20) years from the passed and adopted date of the Permit unless otherwise lawfully terminated in accordance with the terms of this Ordinance.

2.3 **Acceptance.** Bluepeak shall accept the Permit granted pursuant hereto by signing this Ordinance and filing same with the City Clerk within sixty (60) days after the passage and final adoption of this Ordinance.

2.4 **Favored Nations.** In the event City enters into or has entered into a Permit of any kind with any Person other than Bluepeak to enter into the Public Ways for the purpose of constructing or operating a Cable System or providing Cable Service or video service to any part of the Service Area, the material provisions thereof shall be reasonably comparable to those contained herein, in order that one operator not be granted an unfair competitive advantage over another, and to provide all parties equal protection under the law.

If another provider of Cable Services, video services or other television services utilizing any system or technology requiring use of the Public Way in the Service Area, is lawfully authorized by any governmental entity or otherwise exempt from obtaining a permit as provided for in this Ordinance in order to provide such services, City hereby agrees that, upon a request from Bluepeak, as a matter of law, Bluepeak's Permit will be modified within thirty (30) days of the granting of such authorization or exemption for the purpose of establishing the same terms and conditions as such person(s) on a competitively neutral basis. Except as specifically provided in this paragraph, neither City nor Bluepeak shall be permitted to take any unilateral action that materially changes the explicit mutual promises and covenants contained in this Permit, and any changes, modifications or amendments to this Permit must be made in writing, signed by City and Bluepeak.

2.5 **Change of Law.** In the event the federal, state, or local law, rules or regulations are amended, modified, or created that have the effect of modifying the terms and conditions of this Permit during the Term or any extension thereof, Bluepeak has the sole option to terminate this Permit upon ninety (90) days' notice to City. Nothing in this Permit shall impair the right of Bluepeak to terminate this Permit and, at Bluepeak's option, negotiate a renewal or replacement franchise, license, consent, certificate or other authorization with any appropriate government entity (such as the State of Oklahoma). To the extent that Bluepeak obtains an authorization to operate a network and serve customers under applicable laws in lieu of this Permit, Bluepeak shall have the right to terminate this Permit upon 90 days prior written notice to City.

2.6 **Renewal of Permit.** Prior to the end of the Permit term, City and Bluepeak agree to enter into good faith negotiations regarding the renewal, modification, and/or extension of this Permit.

SECTION 3: Standards of Service

3.1 **Conditions of Street Occupancy.** All transmission and distribution structures, poles, other lines, and equipment installed or erected by Bluepeak pursuant to the terms hereof shall be located so as to cause a minimum of interference with the proper use of Public Ways and with the rights and reasonable convenience of property owners who own property that adjoins any of such Public Ways. Bluepeak shall comply with all right-of-way and easement management ordinances and/or regulations enacted by City, including such ordinances and/or regulations enacted after the effective date of this Permit.

3.2 **Restoration of Public Ways.** If during the course of Bluepeak's construction, operation, or maintenance of the Cable System there occurs a disturbance of any Public Way by Bluepeak, it shall, at its expense, replace and restore such Public Way to a condition reasonably comparable to the condition of the Public Way existing immediately prior to such disturbance.

3.3 **Relocation at Request of Permitting Authority.** Upon its receipt of reasonable advance notice, Bluepeak shall, at its own expense, protect, support, temporarily disconnect, relocate in the Public Way, or remove from the Public Way, any property of Bluepeak when lawfully required by City by reason of traffic conditions, public safety, street abandonment, freeway and street construction, change or establishment of street grade, installation of sewers, drains, gas or water pipes, or any other type of structures or improvements by; City; but, Bluepeak

shall in all cases have the right of abandonment of its property. If public funds are available to any company using such street, easement, or right of way for the purpose of defraying the cost of any of the foregoing, such funds shall also be made available to Bluepeak.

3.4 **Relocation at Request of Third Party.** Bluepeak shall, on the request of any Person holding a building or other structure moving permit issued by City, temporarily raise or lower its wires to permit the moving of such building or other structure, provided: (a) the expense of such temporary raising or lowering of wires is paid by such Person, including, if required by Bluepeak, making such payment in advance; and (b) Bluepeak is given not fewer than ten (10) business days' advance written notice to arrange for such temporary wire changes.

3.5 **Trimming of Trees and Shrubbery.** Bluepeak shall have the authority to trim trees or other natural growth overhanging any of its Cable System in the Service Area so as to prevent branches from coming in contact with Bluepeak wires, cables, or other equipment. Bluepeak shall reasonably compensate City or property owner for any damages caused by such trimming.

3.6 **Safety Requirements.** Construction, installation, and maintenance of the Cable System shall be performed in an orderly and workmanlike manner. All such work shall be performed in substantial accordance with applicable FCC or other federal, state, and local regulations. The Cable System shall not unreasonably endanger or interfere with the safety of persons or property in the Service Area.

3.7 **Aerial and Underground Construction.** In those areas of the Service Area where all of the transmission or distribution facilities of the respective public utilities providing telephone communications and electric services are underground, Bluepeak likewise shall construct, operate, and maintain all of its transmission and distribution facilities underground; provided that such facilities are actually capable of receiving Bluepeak's cable and other equipment without technical degradation of the Cable System's signal quality. In those areas of the Service Area where the transmission or distribution facilities of the respective public utilities providing telephone communications and electric services are both aerial and underground, Bluepeak shall have the sole discretion to construct, operate, and maintain all of its transmission and distribution facilities, or any part thereof, aerially or underground. Nothing contained in this paragraph shall require Bluepeak to construct, operate, and maintain underground any ground-mounted appurtenances such as subscriber taps, line extenders, system passive devices (splitters, directional couplers), amplifiers, power supplies, pedestals, or other related equipment. Notwithstanding anything to the contrary contained in this paragraph, in the event that all of the transmission or distribution facilities of the respective public utilities providing telephone communications and electric services are placed underground after the effective date of this Ordinance, Bluepeak shall only be required to construct, operate, and maintain all of its transmission and distribution facilities underground if it is given reasonable notice and access to the public utilities' facilities at the time that such are placed underground.

3.8 **Subscriber Charges for Extensions of Service.** If a Subscriber's residence is located within 125 feet of Bluepeak's feeder cable, the Cable Service will be provided at Bluepeak's published rate for standard installations. However, if such residence is located farther than 125 feet from Bluepeak's nearest feeder cable, then Bluepeak shall only be required to extend

the Cable System to Subscribers in that area if the Subscribers are willing to pay the capital costs of extending the Cable System. Bluepeak may require that such Subscribers pay the capital contribution for construction in advance. Subscribers also shall be responsible for any standard/non-standard installation charges to extend the Cable System from the tap to the residence. Cable Service offered to Subscribers pursuant to this Article shall be conditioned upon Bluepeak having legal access to any such Subscriber's dwelling unit or other units wherein such Cable Service is provided. Nothing herein shall be construed to limit Bluepeak's ability to offer or provide bulk rate discounts or promotions.

3.9 **Pole Attachments.** Utility poles owned by City or an affiliated entity shall be available for use by Bluepeak. Bluepeak shall pay City the maximum cable services pole rental rate as determined by the rules of the FCC for the use of poles owned by City or its affiliate, but not to exceed the amount paid by any other Cable Service provider attaching to such poles pursuant to a current and effective pole agreement.

SECTION 4: Regulation by Permitting Authority

4.1 **Permit Fee.** During the term of this Permit, Bluepeak shall pay to City a fee equal to five percent (5%) of the gross revenues that Bluepeak and its affiliates collected from each subscriber to Bluepeak's Cable Services, and five percent (5%) of the portion of gross revenues from advertising which are defined below the fee ("Permit Fee"). The Permit Fee may be identified and passed through on any subscriber bill by Bluepeak, and all such fees collected will be forwarded to City quarterly and shall be due forty-five (45) days after the end of each calendar quarter.

(A) For purposes of this Permit, gross revenues are limited to the following:

- (1) recurring charges for Cable Services;
- (2) event-based charges for Cable Services, including but not limited to pay-per-view and video-on-demand charges;
- (3) rental of set top boxes and other Cable Services equipment;
- (4) service charges related to the provision of Cable Services, including, but not limited to, activation, installation, and repair;
- (5) administrative charges related to the provision of Cable Services, including, but not limited to, service order and service termination charges; and
- (6) amounts billed to Cable Services subscribers to recover the Permit Fee authorized by this section.

(B) For purposes of this Permit, gross revenues do not include:

- (1) uncollectible fees, provided that all or part of uncollectible fees which is written off as bad debt but subsequently collected, less expenses of collection, shall be included in gross revenues in the period collected;

- (2) late payment fees;
- (3) revenues from contracts for in-home maintenance service unless they relate solely to maintenance on equipment used only for the provisioning of Cable Services and not for the provisioning of any other service provided by Bluepeak or its affiliates;
- (4) amounts billed to Cable Services subscribers to recover taxes, fees or surcharges imposed upon Cable Services subscribers in connection with the provision of Cable Services, other than the Permit Fee authorized by this section;
- (5) revenue from the sale of capital assets or surplus equipment; or
- (6) charges, other than those described in subsection (A), that are aggregated or bundled with amounts billed to Cable Services subscribers.

(C) Gross revenues which are subject to the Permit Fee paid by Bluepeak additionally include a pro rata portion of all revenue collected by Bluepeak pursuant to compensation arrangements for advertising (less any commissions Bluepeak receives from any third parties for advertising) and home-shopping sales derived from the operation of Bluepeak's Cable System within the Service Area. Advertising commissions paid to third parties (excluding any refunds, rebates, or discounts the Company may make to advertisers) shall not be deducted from advertising revenue included in gross revenue. The allocation of advertising and home-shopping revenue referred to above shall be based on the number of subscribers in City divided by the total number of subscribers in relation to the relevant regional or national compensation arrangement.

(D) Bundling discounts shall be apportioned fairly among video and other services. Bluepeak shall not apportion revenue in such a manner as to avoid the Permit Fee.

(E) The Permit Fee shall not apply to Internet access or Internet-based telephone services offered by Bluepeak. If the FCC or any other federal or state governmental authority with jurisdiction to do so authorizes the collection of such a fee during the term of this Permit, then Bluepeak shall, upon reasonable notice of the imposition of such a fee by City that applies equally to all Internet access or Internet-based telephone service providers within the Service Area, commence remittance of a fee in the amount of not more than five percent (5%) of the gross revenues collected from the sale of such Internet access or Internet-based telephone services during the remaining term of this Permit; provided that City and Bluepeak agree to the specific amount in an amendment to this Ordinance/Permit. *This exclusion shall not apply to the payment of statutory "911" fees; such fees shall be collected and remitted by Bluepeak beginning the effective date of this Permit as required by applicable law.*

(F) In the event that any other video services provider, including but not limited to a cable operator or open video service provider, enters into any agreement or makes any arrangement with City during the term of this Permit whereby it is required or allowed to pay a fee to City that is similar to the Permit Fee described herein, this Permit shall be amended to allow Bluepeak to substitute the definition of "gross revenue" set forth in that agreement or arrangement for the definition of "gross revenue" set forth in this Permit immediately upon request of Bluepeak.

Bluepeak and City agree that the Permit Fee shall be in lieu of all other concessions, charges, excises, franchise, license, privilege, permit fees, taxes, or assessments except sales taxes, personal or real property taxes, and act valorem taxes.

4.2 **Rates and Charges.** City may not regulate the rates for the provision of Cable Service or other service, including, but not limited to, ancillary charges relating thereto, except as expressly provided herein and except as may be authorized pursuant to federal and state law. From time to time, and at any time, Bluepeak has the right to modify its rates and charges, at its discretion and without consent of City, including, but not limited to, the implementation of additional charges and rates; provided, however, that Bluepeak shall give notice to City of any such modifications or additional charges thirty (30) days prior to the effective date thereof.

4.3 **Conditions of Sale.** Except to the extent expressly required by federal or state law, if a renewal or extension of the Permit is denied or the Permit is lawfully terminated, and City either lawfully acquires ownership of the Cable System or by its actions lawfully effects a transfer of ownership of the Cable System to another party, any such acquisition or transfer shall be at a fair market value, determined on the basis of the Cable System valued as a going concern.

Bluepeak and City agree that in the case of a lawful revocation of the Permit, at Bluepeak's request, which shall be made in its sole discretion, Bluepeak shall be given a reasonable opportunity to effectuate a transfer of its Cable System to a qualified third party. City further agrees that during such a period of time, it shall authorize Bluepeak to continue to operate pursuant to the terms of its prior Permit; however, in no event shall such authorization exceed a period of time greater than six (6) months from the effective date of such revocation. If, at the end of that time, Bluepeak is unsuccessful in procuring a qualified transferee or assignee of its Cable System which is reasonably acceptable to City, Bluepeak and City may avail themselves of any rights they may have pursuant to federal or state law; it being further agreed that City's continued operation of its Cable System during the six (6)-month period shall not be deemed to be a waiver, nor an extinguishment of; any rights of either City or Bluepeak. Notwithstanding anything to the contrary set forth in this paragraph, neither City nor Bluepeak shall be required to violate federal or state law.

4.4 **Transfer of Permit.** All of the rights and privileges and all of the obligations, duties and liabilities created by this Permit shall pass to and be binding upon the successors of City and the successors and assigns of Bluepeak and the same shall not be assigned or transferred without the written approval of the City Council, which approval shall not be unreasonably withheld, conditioned or delayed; provided, however, that this Section shall not prevent the assignment or hypothecation of the Permit by Bluepeak as security for debt without such approval; and provided further that transfers or assignments of this Permit between any parent and subsidiary corporation or between entities of which at least fifty percent (50%) of the beneficial ownership is held by the same person, persons, or entities which are controlled or managed by the same person, persons, or entities, shall be permitted without the prior approval of City ("intracompany transfers"). Bluepeak shall notify City in writing within thirty (30) days of the closing of such intracompany transfer.

SECTION 5: Compliance and Monitoring

5.1 **Books and Records.** Bluepeak agrees that City may review such of Bluepeak's books and records, during normal business hours and on a nondisruptive basis, as are reasonably necessary to monitor compliance with the financial terms hereof. Such records include, but are not limited to, any public records required to be kept by Bluepeak pursuant to the rules and regulations of the FCC. Notwithstanding anything to the contrary set forth herein, Bluepeak shall not be required to disclose information which it reasonably deems to be proprietary or confidential in nature. City agrees to treat any information disclosed to it by Bluepeak as confidential, to the extent not prohibited by law, and to disclose it only to employees, representatives, and agents of City that have a need to know, or in order to enforce the provisions hereof.

SECTION 6: Insurance, Indemnification, and Bonds or Other Surety

6.1 **Insurance Requirements.** Bluepeak shall maintain in full force and effect during the term of the Permit, at its own cost and expense, Comprehensive General Liability Insurance in the amount of at least \$1,000,000. Such insurance shall designate City as an additional insured to the liability limits imposed by the Oklahoma Governmental Tort Claims Act, 51 O.S. §151, *et seq.*

6.2 **Indemnification.** Bluepeak agrees to indemnify, save and hold harmless, and defend City, its officers, boards and employees, from and against any liability for damages and for any liability or claims, in each case resulting from property damage or bodily injury (including accidental death) which arise out of Bluepeak's construction, operation or maintenance of its Cable System, including, but not limited to, reasonable attorneys' fees and costs.

6.3 **Bonds and other Surety.** Except as expressly provided herein, Bluepeak shall not be required to obtain or maintain bonds or other surety as a condition of being awarded the Permit or continuing its existence. City acknowledges that the legal, financial, and technical qualifications of Bluepeak are sufficient to afford compliance with the terms of the Permit and the enforcement thereof. Bluepeak and City recognize that the costs associated with bonds and other surety may ultimately be borne by the Subscribers in the form of increased rates for Cable Service or other service. In order to minimize such costs, City agrees to require bonds and other surety only in such amounts and during such times as there is a reasonably demonstrated need therefor. City agrees that in no event, however, shall it require a bond or other related surety in an aggregate amount greater than \$100,000 conditioned upon the substantial performance of the material terms, covenants, and conditions of the Permit. Initially, no bond or other surety shall be required. In the event that one is required in the future, City agrees to give Bluepeak at least sixty (60) days' prior written notice thereof stating the exact reason for the requirement. Such reason must demonstrate a change in Bluepeak's legal, financial, or technical qualifications which would materially prohibit or impair its ability to comply with the terms of the Permit or afford compliance therewith.

SECTION 7: Emergency Alert

7.1 **Emergency Alert.** Bluepeak shall comply with the federal Emergency Alert System regulations (47 C.F.R. Part 11).

SECTION 8: Miscellaneous Provisions

8.1 **Preemption.** If the FCC or any other federal or state body or agency shall now or hereafter exercise any paramount jurisdiction over the subject matter of the Permit, then, to the extent such jurisdiction shall preempt and supersede or preclude the exercise of the like jurisdiction by City, the jurisdiction of City shall cease and no longer exist.

8.2 **Employment Requirements.** Bluepeak shall afford equal opportunity in employment to all qualified persons. No person shall be discriminated against in employment because of race, color, sex, religion, gender, national origin, age, familial status or disability. Bluepeak shall maintain and carry out a continuing program of specific practices designed to assure equal opportunity in every aspect of its employment policies and practices.

8.3 **Notice.** Unless otherwise provided by federal, state or local law, all notices, reports or demands pursuant to this Ordinance/Permit shall be in writing and shall be deemed to be sufficiently given upon delivery to a Person at the address set forth below, or by U.S. certified mail, return receipt requested, or by nationally or internationally recognized courier service (such as Federal Express). If questioned, the party sending a notice shall have the burden to prove receipt or rejection. Rejected notices shall be deemed delivered. The parties may designate such other address or addresses from time to time by giving notice to the other in the manner provided for in this section.

To City: City Clerk
 City of Pryor Creek
 12 North Rowe Street
 Pryor Creek, Oklahoma 74631

To Bluepeak: Bluepeak
 4600 S. Ulster St., Suite 1300
 Denver, CO 80237
 Attn: Legal Notices

Email Copy to: Compliance.Team@myBluepeak.com

8.4 **Descriptive Headings.** The captions to Sections contained herein are intended solely to facilitate the reading thereof. Such captions shall not affect the meaning or interpretation of the text herein.

8.5 **Severability.** If any Section, sentence, paragraph, term, or provision hereof is determined to be illegal, invalid, or unconstitutional, by any court of competent jurisdiction or by any state or federal regulatory authority having jurisdiction thereof, such determination shall have no effect on the validity of any other Section, sentence, paragraph, term or provision hereof, all of which shall remain in full force and effect for the term of the Permit or any renewal or renewals thereof.

8.6 **Force Majeure.** Bluepeak shall not be held in default under, or in noncompliance with, the provisions of the Permit, nor suffer any enforcement or penalty relating to noncompliance

or default, where such noncompliance or alleged defaults occurred or were caused by circumstances reasonably beyond the ability of Bluepeak to control. This provision includes, but is not limited to, severe or unusual weather conditions, fire, flood, or other acts of God, strikes, work delays caused by failure of utility providers to service, maintain or monitor their utility poles to which Bluepeak's Cable System is attached, as well as unavailability of materials and/or qualified labor to perform the work necessary.

PASSED, APPROVED AND ADOPTED BY THE _____ CITY COUNCIL
THIS _____ DAY OF _____, 2026.

By: _____

Title: Mayor

(SEAL)

ATTEST:

By: _____, City Clerk

APPROVED AS TO FORM AND LEGALITY THIS _____ DAY OF _____,
2026.

By: _____

Title: City Attorney

ACCEPTANCE BY PERMIT HOLDER

Accepted this _____ day of _____, 202, subject to applicable federal, state and local law.

CLARITY TELECOM, LLC (D/B/A BLUEPEAK)

By: _____

Name: _____

Title: _____